



# Southern Ocean Cloud and Aerosol data: a compilation of measurements from the 2018 Southern Ocean Ross Sea Marine Ecosystems and Environment voyage

Stefanie Kremser<sup>1</sup>, Mike Harvey<sup>2</sup>, Peter Kuma<sup>3,11</sup>, Sean Hartery<sup>3</sup>, Alexia Saint-Macary<sup>2,10</sup>, John McGregor<sup>2</sup>, Alex Schuddeboom<sup>3</sup>, Marc von Hobe<sup>5</sup>, Sinikka T. Lennartz<sup>6</sup>, Alex Geddes<sup>4</sup>, Richard Querel<sup>4</sup>, Adrian McDonald<sup>3</sup>, Maija Peltola<sup>7</sup>, Karine Sellegri<sup>7</sup>, Israel Silber<sup>9</sup>, Cliff S. Law<sup>2,10</sup>, Connor J. Flynn<sup>8</sup>, Andrew Marriner<sup>2</sup>, Thomas C. J. Hill<sup>12</sup>, Paul J. DeMott<sup>12</sup>, Carson C. Hume<sup>12</sup>, Graeme Plank<sup>3</sup>, Geoffrey Graham<sup>3</sup>, and Simon Parsons<sup>3</sup>

<sup>1</sup>Bodeker Scientific, Alexandra, New Zealand

<sup>2</sup>National Institute of Water and Atmospheric Research (NIWA), Wellington, New Zealand

<sup>3</sup>University of Canterbury, Christchurch, New Zealand

<sup>4</sup>National Institute of Water and Atmospheric Research (NIWA), Lauder, New Zealand

<sup>5</sup>Institute for Energy and Climate Research (IEK-7), Forschungszentrum Jülich GmbH, Jülich, Germany

<sup>6</sup>Institute for Chemistry and Biology of the Marine Environment, University of Oldenburg, Oldenburg, Germany

<sup>7</sup>Université Clermont Auvergne, CNRS, LaMP, Clermont-Ferrand, France

<sup>8</sup>School of Meteorology, University of Oklahoma, Norman, USA

<sup>9</sup>Department of Meteorology and Atmospheric Science, Pennsylvania State University, University Park, USA

<sup>10</sup>Department of Marine Science, University of Otago, Dunedin, New Zealand

<sup>11</sup>Peter Kuma Software & Science, Christchurch, New Zealand

<sup>12</sup>Department of Atmospheric Science, Colorado State University, Fort Collins, USA

**Correspondence:** Stefanie Kremser (stefanie@bodekerscientific.com)

**Abstract.** Due to its remote location and extreme weather conditions, atmospheric in situ measurements are rare in the Southern Ocean. As a result, aerosol–cloud interactions in this region are poorly understood and remain a major source of uncertainty in climate models. This, in turn, contributes substantially to persistent biases in climate model simulations, numerical weather prediction models and reanalyses. It has been shown in previous studies that in situ and ground-based remote sensing measurements across the Southern Ocean are critical for complementing satellite data sets due to the importance of boundary layer and low-level cloud processes. These processes are poorly sampled by satellite-based measurements which are typically obscured by near-continuous overlying cloud cover observed in this region. In this work we present a comprehensive set of ship-based aerosol and meteorological observations collected on the TAN1802 voyage of R/V Tangaroa across the Southern Ocean, from Wellington, New Zealand, to the Ross Sea, Antarctica. The voyage was carried out from 8 February to 21 March, 2018. Many distinct, but contemporaneous, data sets were collected throughout the voyage. The compiled data sets include measurements from a range of instruments, such as (i) meteorological conditions at the sea surface and profile measurements; (ii) the size and concentration of particles; (iii) trace gases dissolved in the ocean surface such as dimethyl sulfide and carbonyl sulfide; (iv) and remotely sensed observations of low clouds. Here, we describe the voyage, the instruments, data processing, and provide a brief overview of some of the data products available. We encourage the scientific community to use these measurements for



15 further analysis and model evaluation studies, in particular, for studies of Southern Ocean clouds, aerosol and their interaction.  
The data sets presented in this study are publicly available at <https://doi.org/10.5281/zenodo.4060237> (Kremser et al., 2020).

## 1 Introduction

The Southern Ocean is the cloudiest region on Earth and is also distant from major anthropogenic sources of aerosol (Haynes  
20 et al., 2011). This makes the Southern Ocean an ideal environment for studying aerosol–cloud interactions (Krüger and Graßl,  
2011; Fossum et al., 2018; Hamilton et al., 2014) and the role of marine aerosol in the radiation budget. The contribution of  
marine aerosol to Earth’s radiation budget is both direct through aerosol scattering and absorption, and indirect via cloud droplet  
activation and their subsequent influences on cloud radiative processes (Murphy et al., 1998; Mulcahy et al., 2008; McCoy  
et al., 2015; Fossum et al., 2018). Marine aerosol can be classified as primary or secondary in origin (Fossum et al., 2018).  
25 Primary aerosols, such as sea spray, are directly injected into the atmosphere when breaking waves entrain air bubbles into  
the ocean surface, which subsequently form whitecaps and burst (Hultin et al., 2010; Salter et al., 2014). Secondary aerosols,  
such as sulfate aerosols, are formed from the nucleation of sulfur-containing gases in a gas-to-particle conversion process. One  
of the main precursors of sulfate aerosol in the marine environment is dimethyl sulfide (DMS), a by-product of an enzymatic  
compound produced within phytoplankton (dimethylsulfoniopropionate, DMSP; Read et al., 2008; Fossum et al., 2018). DMS  
30 is the main natural source of atmospheric sulfur, with a global average of 28.1 Tg of sulfur being emitted annually from the  
oceans into the atmosphere in the form of DMS (Lana et al., 2011). When DMS is emitted into the atmosphere, it undergoes  
a series of chemical reactions to form sulfur dioxide (SO<sub>2</sub>), resulting in a typical lifetime of DMS in the atmosphere of 1–2  
days (e.g. Chen et al., 2018). The SO<sub>2</sub> can then be further oxidised to form sulfuric acid, sulfate aerosol and methanesulfonic  
acid (MSA; e.g. Yan et al., 2020). Aerosol emitted into the atmosphere can grow in size via condensation and coagulation. The  
35 ability of any aerosol particle to serve as a nucleus for water droplet formation depends on its size, chemical composition, the  
local supersaturation, and meteorological conditions such as the cloud base updraft velocity (Rosenfeld et al., 2014). Aerosol  
has a significantly different impact on cloud formation and evolution, depending on whether it acts as an ice nucleating particle  
(INP), a cloud condensation nuclei (CCN), or both.

Despite their significant influence on climate, clouds still represent the largest source of uncertainty in modern climate  
40 models with aerosol–cloud interactions being a major factor in this uncertainty (Myhre et al., 2013; Haynes et al., 2011). For  
example, Hyder et al. (2018) recently identified that 70 % of the sea surface temperature biases observed in model simulations,  
performed in support of the Coupled Model Intercomparison Project 5 (CMIP5), can be attributed to the models not represent-  
ing clouds and their properties correctly. These errors occur because climate models simulate too little cloud cover and contain  
biases in cloud albedo over the Southern Ocean (Bodas-Salcedo et al., 2012; Schuddeboom et al., 2019), resulting in projec-  
45 tions that underestimate the reflected solar radiation at the top of the atmosphere (TOA; Haynes et al., 2011) and overestimate



downwelling solar radiation at the ocean surface. This leads to excessive sunlight being absorbed by the ocean (Trenberth and Fasullo, 2010; Kay et al., 2016; Hyder et al., 2018) and subsequent higher sea surface temperatures than observed (Bodas-Salcedo et al., 2012; Mechoso et al., 2016). Previous studies have also shown the importance of accurate mixed-phase cloud parameterisations over the Southern Ocean in climate models to properly simulate cloud radiative properties over the Southern Ocean (Lawson and Gettelman, 2014; Kay et al., 2016; Schuddeboom et al., 2019; Noh et al., 2019). In mixed-phase clouds, both liquid droplets and ice crystals coexist with the liquid water often being supercooled. While observations in the Southern Ocean are sparse, measurements reported by McCluskey et al. (2018), DeMott et al. (2018), and Welti et al. (2020) indicate that INP concentrations are exceptionally low over the Southern Ocean, much lower than previously estimated by Bigg (1973). The low concentrations of INPs over the Southern Ocean limit cloud droplet freezing, reduce precipitation, and enhance cloud reflectivity compared to regions of higher INP abundance (e.g. Vergara-Temprado et al., 2018). This indicates that an accurate representation of INPs in climate models is necessary to properly simulate cloud radiative properties over the Southern Ocean. For example, climate models often produce too many ice crystals in mixed phase clouds that consume the liquid droplets and thereby change the radiative properties of clouds (Kay et al., 2016).

Reducing the uncertainty in the simulation of aerosol–cloud interactions requires detailed observational data sets against which models can be evaluated. However, this process is hindered over the Southern Ocean by the lack of ground-based and in situ measurements. While satellite-based measurements can provide some data over the region, they cannot provide detailed aerosol chemical composition data or be solely relied upon to examine low-level clouds (Kuma et al., 2020; McErlich et al., 2020). There have been only a limited number of ship- and ground-based field campaigns over the Southern Ocean (see Table 1 for an overview). Observational campaigns which provide detailed measurements of low-level cloud, aerosol, aerosol precursors, INPs, and CCN are essential for model evaluation, especially for parameters that can be indirectly estimated, but not accurately determined from satellite-based measurements.

In this paper we present a new data set of atmospheric (cloud, aerosol and thermodynamic properties) and seawater measurements that were collected during the six-week Southern Ocean Ross Sea Marine Ecosystem and Environment voyage (TAN1802) from Wellington, New Zealand, to the Ross Sea, Antarctica, in 2018. Given the sparsity of data in the Southern Ocean region, this data set provides a valuable collection of atmospheric and underway measurements that can be used to better understand aerosol–cloud processes over the Southern Ocean. This paper includes a description of DMS and carbonyl sulfide (OCS) measurements as previous work has identified that DMS plays an important role as a sulfate aerosol precursor. Furthermore, DMS concentrations have a particularly large impact on model aerosol forcings, yet are poorly represented in climate models (Hoffmann et al., 2016; Bodas-Salcedo et al., 2019). Although not strictly related to aerosol–cloud interactions, OCS is a greenhouse gas and an important source of stratospheric sulfate aerosol (Crutzen, 1976; Brühl et al., 2012; Kremser et al., 2016). Ocean emissions represent the largest known single OCS source and process models predict the highest open ocean OCS fluxes in the Southern Ocean (Kettle et al., 2002; Lennartz et al., 2017). As the TAN1802 voyage was only the second research cruise probing OCS in the Southern Ocean, and the first with sufficiently high temporal resolution to thoroughly test and improve the existing models, we include the OCS measurements in the data set accompanying this paper.



**Table 1.** List of previous ship- and ground-based field campaigns related to aerosol–cloud interactions over the Southern Ocean.

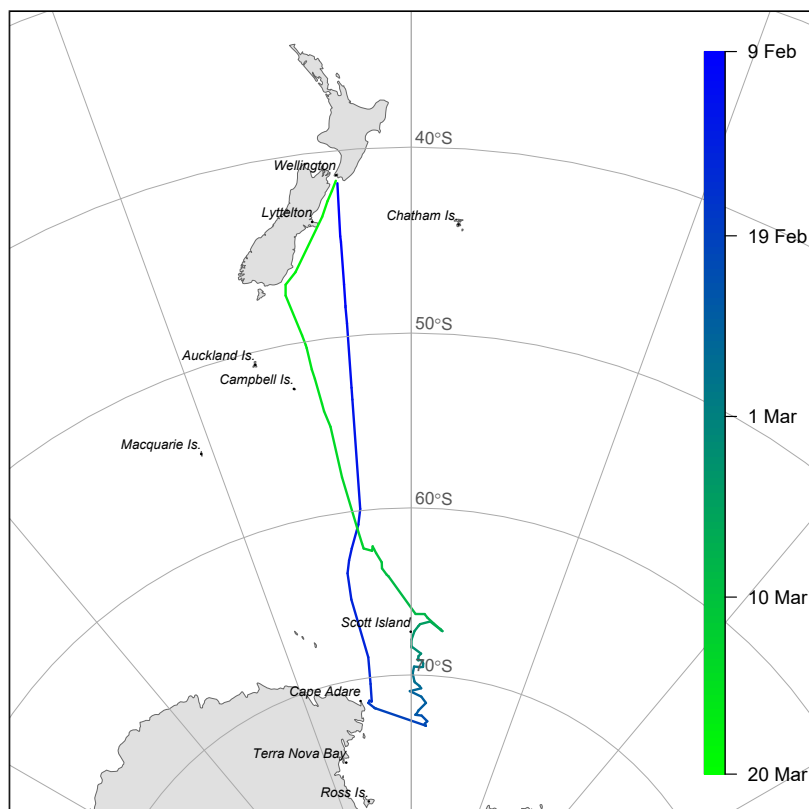
Campaign name	Year	Reference
British Southern Ocean cruise (BSO)	Oct 1992–Jan 1993	O’Dowd et al. (1997)
Aerosol Characterization Experiment (ACE I)	Nov–Dec 1995	Bates et al. (1998)
Finnish Antarctic Research Program (FINNARP)	Nov–Dec 2004	Vana et al. (2007)
Surface Ocean Aerosol Production (SOAP)	Feb–Mar 2012	Law et al. (2017)
Sea Ice Physics and Ecosystem Experiment (SIPEX II)	Sep–Nov 2012	Humphries et al. (2016)
PEGASO voyage of R/V BIO Hesperides	Jan–Feb 2015	Fossum et al. (2018)
R/V Investigator trial voyage into the Southern Ocean	Jan–Feb 2015	Alroe et al. (2020)
Clouds, Aerosols, Precipitation, Radiation, and atmospheric Composition Over the southeRn ocean (CAPRICORN I and II)	Mar 2015 Mar–Apr 2016	Protat et al. (2017) Mace and Protat (2018)
Antarctic Circumnavigation Expedition (ACE 2016/17)	Dec 2016–Mar 2017	Schmale et al. (2019)
Chinese Antarctic Research voyages by R/V Xuelong	Dec 2017 Jan–Feb 2018	Yan et al. (2020)
Measurements of Aerosols, Radiation, and Clouds over the Southern Ocean (MARCUS)	Oct 2017–April 2018	McFarquhar et al. (2019)
Macquarie Island Cloud and Radiation Experiment field campaign (MICRE)	Mar 2016–Mar 2018	Marchand (2020)

## 80 2 TAN1802 voyage – New Zealand to the Ross Sea

The 2018 Southern Ocean Ross Sea Marine Ecosystem and Environment voyage, TAN1802, was a voyage with NIWA’s (National Institute of Water and Atmospheric Research) research vessel Tangaroa from Wellington to the Ross Sea, between 8 February and 21 March 2018. The purpose-built research vessel is 70 m long, with a beam width of 13.8 m and a draught of 7 m. It can accommodate 40 people, including a mix of research staff and ship personnel. The specifications and principal  
85 features of the vessel are described at the *NIWA website*. Over the course of the TAN1802 voyage, the R/V Tangaroa travelled 11,000 km and spent the majority of its time, i.e. 30 days, south of 60° S (Fig. 1).

### 2.1 Voyage objectives

One of the seven overarching research objectives of the TAN1802 voyage was to take atmospheric observations and samples to investigate interactions between marine aerosols and cloud formation over the Southern Ocean, thereby improving our



**Figure 1.** The ship track of the R/V Tangaroa with dates indicated by colours. The 2018 Southern Ocean Ross Sea Marine Ecosystem and Environment voyage extended from the North Island of New Zealand to off the coast of Cape Adare (Antarctica).

90 understanding of aerosol–cloud interactions in this region. This study focuses on describing the ship-based measurements that were made in support of this research objective with the goal to:

- Characterise low/medium level clouds, aerosol, and radiation from ship-based continuous measurements using lidar, ceilometer, and sky cameras.
- Characterise aerosol sources which have a controlling influence on cloud properties through measurements of size, chemistry, and nucleating properties.
- Investigate the importance of sea-salt and other primary aerosols as CCN.
- Investigate the influence of local biogenic sulfur emissions to secondary aerosol abundance.

95

- Measure boundary layer profiles of aerosol and thermodynamic properties through combination of lidar measurements and radiosonde flights and evaluate coupling between surface measured aerosol and low-level cloud capping within the marine boundary layer.

100



- Link aerosol and surface trace gas properties to surface water biogeochemistry.

All measurements that were made to address the research objective are summarised in Table 2 and a detailed description of the instrumentation and their measurements is given below.

## 2.2 Meteorological conditions throughout the voyage

105 Meteorological measurements, including 1 minute records of air temperature, dew-point temperature, pressure, wind speed, wind direction, relative humidity (RH), sea surface temperature, downwelling shortwave and downwelling infrared radiation were made during the voyage using underway sensors and the automated weather station (AWS) installed on the ship. The vessel reports meteorological and oceanographic data through the Integrated Marine Observing System (IMOS, Smith et al., 2018). The AWS anemometer was positioned at 25.2 m above sea level (ASL) on the mast of the ship, while the other parts of  
110 the AWS were positioned at 15 m ASL. Measurements of the average relative wind speed and wind direction were made using a pair of ultrasonic anemometers (Gill WindSonic), reporting at 1 minute intervals. The Tangaroa Data Acquisition System (DAS) recorded Global Positioning System (GPS) coordinates, all AWS measurements, ship's hull sensor measurements, and other variables such as attitude (pitch and roll) every minute.

Data stored in the DAS were further processed as indicated in Fig. 2, before their use in, for example, sea-air flux calculations for DMS and OCS (Sect. 4.3.1 and Sect. 4.3.2). The wind speed measurements were corrected to wind speed at 10 m  
115 reference height ( $u_{10}$ ) according to directionally dependent acceleration factors, based on a model of air flow around Tangaroa's superstructure (Popinet et al., 2004). The wind speeds were then corrected according to the ship heading and speed to derive the true wind speed and direction. A pair of shortwave radiometers (0.285 to 2.8  $\mu\text{m}$  - Eppley Precision Spectral Pyranometer, PSP) and a second pair of downwelling infrared radiometers (4 to 50  $\mu\text{m}$  - Eppley Lab Precision Infrared radiometer, PIR)  
120 are installed on the ship. The pairing of the instruments enabled corrections to the measurements to be made by accounting for shadowing by the ship. The meteorological measurements together with dissolved DMS measurements (Sect. 3.10.1) were used as inputs to the National Oceanic and Atmospheric Administration (NOAA) Coupled Ocean–Atmosphere Response Experiment (COARE) meteorological and gas exchange algorithm to derive meteorological values for standard reference heights (e.g.  $u_{10}$ ), energy and gas exchange coefficients and sea-air fluxes of DMS (Sect. 4.3.1).

125 AWS measurements were complemented by human weather observations, all-sky cameras, ceilometer, Mini–Micropulse lidar, and micro rain radar measurements, which provided important information about visibility, sky conditions, clouds, cloud type, and the amount of precipitation or fog events. In addition, up to three daily regular radiosondes of type InterMet iMet-1-ABxn were launched throughout the voyage, as well as smaller balloons carrying Windsond radiosondes that were launched in synoptically interesting conditions, e.g. within low pressure systems (Sect. 3.1.1). An overview of all radiosonde releases  
130 during the voyage is provided in Table B1 and B2.

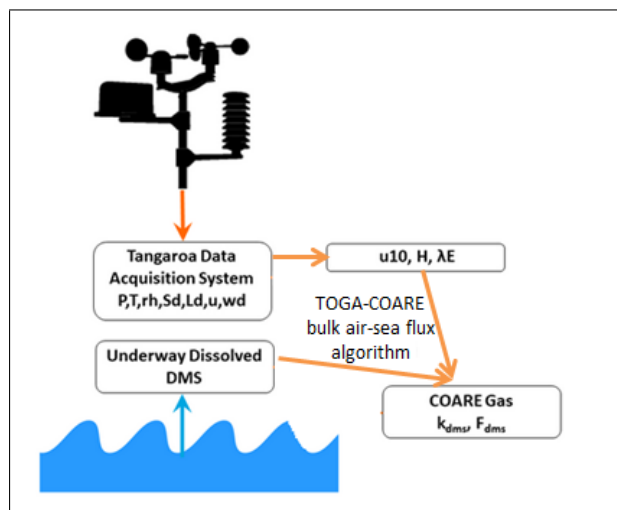
All meteorological data are available in netCDF format at UTC times and are provided with the data set accompanying this study. Section 4.1 below provides some detail about the meteorological conditions encountered during the voyage.



**Table 2.** Table of instruments related to aerosol–cloud interactions that were deployed on the R/V Tangaroa and are described in this study.

Instrument	Type	Location on the ship	Parameter	Section
InterMet iMet-1-ABxn	Radiosonde	Fantail	pressure, temperature, RH, wind, GPS	3.1.1
Windsond	Radiosonde (ascent and descent)	Fantail	pressure, temperature, RH, wind, GPS	3.1.1
Lufft CHM 15k	Ceilometer	Gilson gantry	backscatter, CBH	3.2
Sigma Space MiniMPL	Mini–Micropulse lidar	Monkey island	backscatter, CBH	3.3
Metek Micro Rain Radar	Rain radar	Port side of gallery	precipitation	3.4
Brinno BCC200	Sky camera	Monkey island	Sky images	3.5
Allskypi	Sky camera	Monkey island	Sky images	3.5
Microtops-2	Sun Photometer	Manual on deck	AOD, water vapour, fine and coarse mode AOD at 500 nm	3.6
Picarro G2301	Cavity Ring–Down Spectrometer	Middle lab	Atmospheric CO <sub>2</sub> , CH <sub>4</sub> , H <sub>2</sub> O	3.7
SwellPro Splash Drone 3	UAV	Foredeck	0.38 to 17 μm, temperature, RH	3.1.2
Helikite	Tethered balloon-kite	Fantail	0.38 to 17 μm, temperature, RH	3.1.3
Filter sampler	Filter	Bridge Mezzanine Deck (front)	Ice nucleating particles	3.9
PCASP-100X	Optical Particle Counter	Container laboratory	0.1 μm < D <sub>p</sub> < 3.0 μm	3.8.1
CCN-100	Cloud Condensation Nuclei Counter	Container laboratory	0.2 % < s < 1.0 %	3.8.2
CPC3010	Condensation Particle Counter	Container laboratory	0.01 μm < D <sub>p</sub> < 3 μm	3.8.3
SMPS3936	Scanning Mobility Particle Size Spectrometer	Container laboratory	0.02 μm < D <sub>p</sub> < 0.5 μm	3.8.4
NAIS	Neutral cluster and air ion spectrometer	Bottom of main mast	2 nm < D <sub>p</sub> < 42 nm	3.8.5
GC-SCD	Gas Chromatograph - Sulfur chemiluminescent detector	Container laboratory	Dissolved DMS	3.10.1
MICA	Mid-Infrared CAvity enhanced spectrometer	Middle laboratory	Atmospheric and dissolved OCS, CO <sub>2</sub> , and CO	3.10.2

\*RH - relative humidity; CBH - cloud base height; AOD - aerosol optical depth; CH<sub>4</sub> - methane; DMS - dimethyl sulfide; OCS - carbonyl sulfide; CO - carbon monoxide



**Figure 2.** Summary of the processing scheme of the meteorological measurements (pressure (P), temperature (T), relative humidity (rh), wind (u), wind direction (wd), short- and longwave downwelling radiation (Sd, Ld)) from the AWS and radiometers measurements that were stored in the Tangaroa Data Acquisition System. Wind corrected to 10 m ( $u_{10}$ ), heat flux (H) and latent heat ( $\lambda E$ ) were derived from these measurements.

### 3 Instrument descriptions

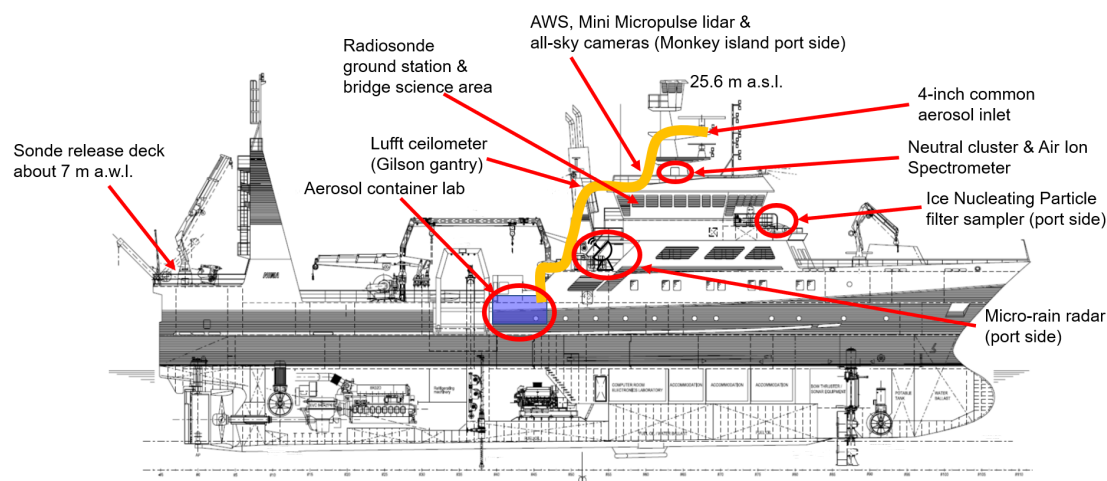
In addition to the instrumentation mentioned above, atmospheric measurements were conducted using a range of instruments, including a cavity ring-down spectrometer, cloud condensation nuclei counter, condensation particle counter, mobility particle size spectrometer, optical particle counter, neutral cluster and air ion spectrometer, a filter sampler, tethered balloon, and an unmanned aerial vehicle (UAV). During rare clear sky conditions, aerosol optical depth (AOD) measurements were made using a hand-held sun photometer. The instrumentation and measurement techniques of each instrument are described below. Furthermore, all data sets described here include some means of quality control and calibration procedures, which are also described below in the respective sections.

#### 3.1 In situ measurements and remote sensing observations

##### 3.1.1 Radiosondes

Radiosondes are balloon-borne instruments that measure the vertical profile of temperature, relative humidity and pressure. Altitude, wind direction and wind speed are calculated from the GPS location of the sonde. A total of 58 radiosondes of type InterMet iMet-1-ABxn (hereafter referred to as iMet) and 12 of type Windsond were released on a weather balloon during the voyage (see Table B1 and B2). The iMet radiosondes were attached to 100 g Kaymont weather balloons and released two to three times per day at about 07:30, 00:00 and 19:30 UTC. The typical height reached by the balloons was between 10 and 20 km ASL. Of the total iMet radiosondes released, one failed right after launch, and one failed at 216 m ASL. In addition, two





**Figure 3.** A diagram showing the locations of the atmospheric measurement equipment on-board R/V Tangaroa. A line pump for the common aerosol inlet was used to pump sample air from above the bridge to the aerosol container lab.

iMet radiosondes had faulty or intermittent relative humidity readings. No iMet radiosondes were released north of 58° S or in  
150 unsuitable weather conditions, e.g. when wind speed was exceeding 35 kn or in high swell. In addition to the iMet radiosondes,  
S1H3 Windsond radiosondes were launched sporadically throughout the voyage. The typical altitude reached by the Windsond  
radiosondes was 6 km. Five of the Windsonds were equipped with a second balloon to perform measurements during the  
descent, but only two descending profiles were successfully measured.

The iMet radiosondes communicated with the base station by radio at 403 MHz and included a pressure sensor with an  
155 accuracy of 0.5 hPa and a resolution of < 0.01 hPa. As described by the manufacturer, a thermistor was used to measure the  
temperature with an accuracy of 0.2 °C and a resolution of ±0.01 °C and a capacitive polymer sensor measuring relative  
humidity with an accuracy of ±5 % and a resolution of <0.1 %.

The lightweight (about 12 g), low operating cost Windsond radiosonde provides real-time wind, temperature, and relative  
humidity profiles in the lower part of the troposphere with an operational ceiling of 9 km ASL. The system has an operational  
160 radio frequency configurable in the range of 400 to 480 MHz. The Windsond use a band-gap temperature sensor with a mea-  
surement range between -40° and +80 °C, an accuracy of 0.2 °C and a resolution of ±0.01 °C. Relative humidity was measured  
using a film capacitor sensor with high accuracy (±1.8 %) and a resolution of 0.05 %. Pressure was measured directly using a  
microelectromechanical piezoresistor pressure sensor with an accuracy of 1 hPa and a resolution of 0.02 hPa. The Windsond  
GPS ground station was not equipped with a GPS receiver; therefore, latitude and longitude was determined using an on-board  
165 GPS receiver pseudorange without differential correction. Wind speed and direction is determined independently from latitude  
and longitude using the GPS signal; wind speed accuracy is about 5 %.



### 3.1.2 Unmanned aerial vehicle – UAV

During the voyage, two UAV flights were performed when the observed wind speed was below  $5 \text{ m s}^{-1}$ . For the first flight, which took place on 4 March 2018, the UAV was equipped with an optical particle counter (OPC) of type Alphasense OPC-N2, a GoPro Hero4 camera and a customised radiosonde. The radiosonde was equipped with a SHT75 temperature and relative humidity sensor. Temperature can be measured between  $-40^\circ$  and  $+40^\circ \text{ C}$  with an accuracy of  $0.3^\circ \text{ C}$  and a resolution of  $\pm 0.01^\circ \text{ C}$  and relative humidity can be measured with an accuracy of 1.8 % and a resolution of 0.05 %. A customised radiosonde was required to be deployed on the UAV (rather than using a standard sonde) as it needed to interface with the OPC-N2 sensor and data had to be transferred over radio to the ground station. The Alphasense OPC-N2 is an OPC designed to count ambient particulate and drizzle sized cloud droplets between  $0.38\text{--}17 \mu\text{m}$  in size. Ambient air is drawn into the sensor by a small rotary micro-fan at a flow rate of about  $1.2 \text{ L min}^{-1}$ . The air enters the front of the device through a 6 mm orifice into an open optical cavity, where red laser light (around 650 nm) is incident on the incoming aerosol. Scattered light from the aerosol is collected via an elliptical mirror and a dual-element photodetector. These measurements are used to determine the particle size and particle number concentration.

While the expected battery lifetime of the UAV was 15 minutes, this was reduced to 6 minutes due to the low atmospheric temperature, resulting in a lower than expected altitude reached and unplanned landing on the ocean surface. After the battery regained enough power to take off again, the UAV was recovered. Measurements of aerosol concentration, temperature, pressure and humidity were recorded up to an altitude of about 70 m. No measurements were retrieved from the second UAV flight due to a faulty assembly of the propellers, which resulted in the loss of the aircraft.

### 3.1.3 Helikite

Similar to the UAV flights, two helikite flights were conducted in suitable weather conditions subject to wind speed of below  $5 \text{ m s}^{-1}$ . For the first flight, the helikite was equipped with an iMet radiosonde and an OPC-N2, providing profiles of aerosol concentration, as well as temperature, pressure and humidity profiles. The second helikite flight had to be terminated shortly after launch as the weather conditions changed rapidly, resulting in no measurements.

The helikite comprised a large  $6 \text{ m}^3$  balloon with a sturdy kite base. Lift can be achieved by inflating the balloon with helium and is aided by the additional lift of the kite. As a result of the large volume of the balloon, the total payload can be around 2 to 3 kg. The helikite was flown off the fantail and was anchored to an electric winch fitted with  $>1 \text{ km}$  of high tensile strength Dyneema line. This system itself offers the opportunity to fly more expensive sampling equipment than typically deployed during a radiosonde flight where equipment is usually not recovered.

The first flight of the helikite occurred midway through the voyage on 26 February 2018. Conditions were good with wind speeds less than  $5 \text{ m s}^{-1}$ . Due to the inexperience of the helikite operator, the helikite was flown in near neutral buoyancy, i.e. the lift provided by the balloon was near or equal to the weight of the payload. As a result, the only lift received during the flight was from the kite alone. Once the helikite left the slipstream of the Tangaroa it rose slowly to an altitude of 260 m. At this



stage, the additional weight of the tethered string counter-balanced all lift. After sampling for around 45 minutes, the system  
200 was reeled back in.

### 3.2 Ceilometer

During the voyage a ceilometer, which is a low-power lidar, made continuous measurements of the overlying atmospheric  
state. The ceilometer deployed on the voyage was a Lufft CHM 15k, which operated at an infrared wavelength of 1064 nm,  
with a maximum range of 15 km. The ceilometer was installed on the Gilson gantry behind the monkey island (Fig. 3), located  
205 approximately 16 m ASL. The ceilometer continually emits short light pulses vertically into the atmosphere, where light is  
scattered back by clouds, aerosol and air molecules. By detecting the run-time of the return signal, the ceilometer identifies  
the lowest altitude of a cloud as the layer with higher particle backscatter characteristics. The backscatter is calculated at  
1024 vertical levels in the atmosphere (about 15 m vertical resolution). By applying detection algorithms using the operational  
software to the backscatter measurements, quantitative information on cloud base height (CBH), cloud fraction (CF), cloud  
210 layers, and boundary layer height can be determined. As the emitted signal is strongly attenuated by thick clouds, it is often  
not possible to observe the middle or tops of clouds. On some occasions, the movements of the ship (pitch and roll) affected  
the ceilometer measurements when there were horizontally inhomogeneous clouds, producing a vertical filament structure in  
the backscatter.

### 3.3 Sigma Space Mini-Micropulse Lidar

215 The Mini-Micropulse Lidar (MiniMPL) is a sophisticated laser remote sensing system that provides continuous, unattended  
monitoring of the profiles and optical properties of clouds and aerosols in the atmosphere. A micropulse lidar (MPL) transmits  
laser pulses that scatter (reflect) off particles in the atmosphere. The MPL then measures the intensity of backscattered light  
using photon-counting detectors and transforms the signal into atmospheric information in real time. During the campaign,  
aerosol backscatter data were collected using the Sigma Space MiniMPL, which is a compact version of the standard MPL  
220 described by Ware et al. (2016). The detection range of the MiniMPL is limited to the upper troposphere/lower stratosphere. The  
maximum range is 30 km but the effective range was lower than that during the voyage. The MiniMPL is a dual-polarisation  
micropulse lidar operating at a wavelength of 532 nm at 2.5 kHz (pulse energy is 3–4  $\mu$ J). Laser light that is scattered back  
towards the instrument is collected by an 80 mm diameter receiver (Spinhirne et al., 1995; Campbell et al., 2002; Flynn et al.,  
2007). The vertical range resolution was set at 15 m during the ship campaign. A two-axis scanning head was mounted on top  
225 of the environmental enclosure containing the lidar, to provide variable-angle scanning throughout the voyage. Azimuth was  
fixed for observations (pointing outward from the side of the ship) and the scanning head was programmed with an elevation-  
only scanning routine that included the following angles: 0, 5, 10, 15, 20, 30, 40, 45, 50, 60, 70, 80, 90° elevation. The finer,  
5° elevation step was used near the horizon, and then 10° steps from 20° to 90° (zenith). An observation was also made at  
45° because it is convenient geometrically. At 0° and 90°, the observations were 12 minutes long, at other angles 6 minutes,  
230 resulting in the full scanning cycle taking 90 minutes. The elevation angle of each particular observation is recorded in the data



file. Note that there were some instances during the campaign when a software failure caused the scanning system to not follow the programmed schedule.

The instrument produces native binary files (“mpl”) with backscatter and housekeeping metadata, which can be converted to netCDF files using manufacturer supplied software (SigmaMPL) or third-party software (*mpl2nc*). The primary output quantity  
235 is the normalised relative backscatter (NRB) profile, representing the backscattering of light (in photon counts  $\text{km}^2\mu\text{s}^{-1}\mu\text{J}$ ), after correcting and normalising the measurements. An auxiliary GPS unit was connected to the lidar, whose output was recorded in the product files. The instrument was installed on the monkey island (Fig. 3).

The instrument ordinarily requires range-dependent calibration of backscatter in the form of dead time, overlap and after-pulse corrections, which account for the saturation of the photon counter, incomplete overlap of the outbound and inbound  
240 beams, and post-pulse reflections from the internal parts of the instrument, respectively. These were supplied by the manufacturer. An improved calibration was produced post-voyage, which addresses a technical issue with the manufacturer calibration (bit truncation of dead time polynomial coefficients) and a change in overlap which might have happened during transport and deployment of the instrument. The data product produced with the third-party *mpl2nc* software was calibrated with the improved calibration and is supplied with the data set.

245 The CHM 15k ceilometer and Sigma Space MiniMPL measurements were both processed using the Automatic Lidar and Ceilometer Framework (ALCF, Kuma et al., 2020). While ALCF was developed to provide a tool to evaluate clouds simulated by climate models or reanalysis data using ceilometer or MiniMPL observations, ALCF can be run independently of any model input to process ceilometer or MiniMPL observations. ALCF can ingest the raw measurements, transform backscatter profiles to profiles comparable with different instruments, and output the results in netCDF format. ALCF is described in detail in  
250 Kuma et al. (2020).

Two different data products are provided for both the ceilometer and MiniMPL data, level 0 and level 1:

- Ceilometer level 0: contains one file per 5 minutes of observations in the native netCDF format (.nc files),
- MiniMPL level 0: contains one file per hour of observations in the native binary (.mpl) format which can be processed using the proprietary SigmaMPL software or converted to netCDF format using a python tool *mpl2nc*.
- 255 – Level 1: contains ALCF processed raw ceilometer and MiniMPL data sets (one file per day) in netCDF format. The data products included are time series of vertical backscatter profiles, backscatter standard deviation, cloud base height, cloud mask, and lidar ratio.

### 3.4 Micro Rain Radar

During the voyage a Metek Micro Rain Radar 2 (MRR-2) made continuous measurements of the overlying atmospheric state  
260 between 7 and 27 February 2018. The MRR-2 is a vertical pointing FM-CW (Frequency-modulated continuous-wave) radar with a centre frequency of 24.23 GHz and a frequency modulation between 0.5–15 MHz. The scatter return signal can be processed to derive Doppler spectra at a number of predefined vertical ranges, from the ground to several hundred meters. For rain droplets, the relationship between terminal fall velocity and drop diameter is used to derive vertical profiles of the rain



drop size distribution from the Doppler spectra. These drop size distributions can be integrated to derive rain rates even for  
265 very small amounts of precipitation, below the thresholds detectable by conventional rain gauges. The software supplied by  
the manufacturer completes all this processing and also makes estimates of other parameters, such as liquid water content. The  
temporal resolution of the measurements is 10 s. Measurements of snowfall using this instrument are more challenging because  
the particle backscattering cross sections depend on both their mass and shape, while terminal velocities relationship to particle  
size depends on their projected area. In the case of snowfall, we use the method of Maahn and Kollias (2012) to process the  
270 raw data to derive radar reflectivity, velocity, spectral width and snowfall rate estimates. The radar was installed on the port  
side of the gallery beneath the bridge (Fig. 3).

### 3.5 Sky cameras

A pair of Brinno BCC200 cameras were installed on the starboard and port side of the monkey island (Fig. 3). The cameras  
were configured to capture an image of the sky every 5 minutes. The resolution of the images is  $1280 \times 720$  pixels, and they  
275 are recorded in a video file (Motion JPEG). These images are complementary to the human weather observations, ceilometer,  
and lidar data to evaluate cloud cover, cloud types and cloud base height during the voyage. An additional camera system,  
named allskypi, was also installed on the monkey island, adjacent to the MiniMPL. The allskypi system contained a ZWO  
ASI178MC ( $3096 \times 2080$  pixels) camera with a fisheye lens connected to a Raspberry Pi single-board computer. Allskypi  
acquired images at 7 exposure levels every 5 minutes, with in post voyage processing combining these exposure stacks into  
280 a single high dynamic range (HDR) image as described in Mertens et al. (2009). Over the course of the voyage over 60,000  
images were taken, resulting in nearly 9,000 HDR images. When combined with ship positioning data, including roll and pitch,  
cloud fraction can be determined by simple thresholding techniques such as the ELIFAN algorithm presented in Lothon et al.  
(2019). This algorithm was adapted to the allskypi system to obtain cloud fractions. Furthermore a record of whether or not  
the sun was obscured by clouds was produced by monitoring the image saturation over the solar disk. All-sky imagery, along  
285 with estimates of cloud fraction and sun obscuration obtained during this voyage were primarily used for quality assurance and  
quality control (QA/QC) of other sky viewing observations such as the ceilometer and MiniMPL measurements (as described  
in, e.g. Wagner and Kleiss, 2016). Cloud fraction derived from the sky camera product is also useful for model evaluation and  
when combined with the raw imagery and ceilometer data it could potentially be used to classify cloud types as described in  
Huertas-Tato et al. (2017).

### 290 3.6 AERONET Maritime Aerosol Network (MAN) hand-held sun photometer

When clear-sky conditions were present, column aerosol measurements were made using a portable sun-pointing Microtops-2  
sun photometer, operating at five wavelengths. The instrument was operated according to Aeronet Maritime Aerosol Network  
protocols with an attached GPS receiver to log positional information. Scans were usually taken in groups of five measurements  
and only made under clear-sky conditions with no clouds present near or around the sun taking care to avoid measurements  
295 through cirrus clouds. Due to the high cloud cover during the voyage, these measurements were performed only four times  
on three distinct days. Processed products include AOD at five wavelengths, water vapour content, the angstrom parameter



and aerosol optical depth for the fine (sub-micron) and coarse (super-micron) modes calculated according to the spectral deconvolution algorithm of O'Neill et al. (2003). The data are available via the *MAN website for the TAN1802 voyage*.

### 3.7 Cavity ring-down spectrometer – Picarro

300 By the voyages nature, the ship did not always head into the wind. As a result, there were distinct times throughout the voyage when winds from the stern outpaced the motion of the ship and therefore the sampling line of air sampling instruments was often exposed to exhaust from the ship. This problem was largely unavoidable, but the ship's measurements of wind-speed and heading combined with high precision measurements of carbon dioxide (CO<sub>2</sub>) were used to identify contamination episodes. Experience from previous voyages (e.g. Law et al., 2017) has shown that the Cavity Ring-Down Spectrometer (CRDS) is  
305 ideally suited to detect ship exhaust contamination. For this and other reasons beyond the scope of this paper, a CRDS (G2301, Picarro) was installed on the ship and operated continuously throughout the voyage. The CRDS was installed in an equipment room off the middle lab (Fig. 3) measuring atmospheric mixing ratios of CO<sub>2</sub> and methane (CH<sub>4</sub>) continuously at 1 Hz. Air for analysis by the CRDS was obtained from an inlet on the Forward Light Tower above the Bridge (~20 m ASL) via an airline to the middle lab. Air was pumped down from the airline at about 2 L min<sup>-1</sup>, of which 150 mL min<sup>-1</sup> (determined by a mass  
310 flow controller) is used for analysis. Before the air from the airline was sampled by the analyser, it was dried to a dew point of 2–4 °C using a thermoelectric cooler and then dried further to a dew point between -30 and -40 °C using a back-flushed Nafion dryer in which remaining water vapour in the air is transferred to the CRDS exhaust air that had been dried by passing it through a molecular sieve trap. While the Picarro instrument does measure the concentration of water vapour in the air, in this system the water vapour measurement was only used as a diagnostic indicator of system performance. Solenoid valves  
315 controlled by the Picarro were used to select either pre-dried air for analysis, or air from one of three reference tanks, plus a target tank, for system calibration. A calibration sequence was automatically run twice per day.

The analyser has a built-in Windows 7 PC for data acquisition and control of the CRDS system. Measurements were stored in the form of hourly text files on the Picarro PC's solid state drive. File times are UTC, whereas the Picarro's internal PC was set to NZST (UTC + 12 h) and was synchronised to Tangaroa's time server. Picarro's sample time is around 1 s (there is  
320 some variability around this value), but this is shared among the three compounds measured (CO<sub>2</sub>, CH<sub>4</sub>, and H<sub>2</sub>O), so the individual compound sample time is around 3 s. Once per day the data files were backed-up to the network drives of the ship and processed to produce diagnostic plots to check system operation and performance.

### 3.8 Common Aerosol Sampling Conduit

Throughout the voyage, the container laboratory, which housed the majority of the underway aerosol sampling instrumentation,  
325 was positioned behind the mid-ships exhaust (2 m ASL). To prevent exhaust air from contaminating the in situ measurements of ambient marine aerosol, ambient air was drawn from the mast of the R/V Tangaroa, through the conduit (Fig. 3) to the container laboratory, at a rate of  $4.1 \times 10^{-2} \text{ m}^3 \text{ s}^{-1}$ . Size-dependent losses of particulate to conduit walls from an-isokinetic sampling, gravity, turbulence, and diffusion are described in detail in Hartery et al. (2020). The average transit time for particulates



through the 40 metre long common aerosol sampling conduit was  $<8$  s. The inlet of the conduit was angled downwards to  
330 prevent the accumulation of precipitation within the inlet region.

The aerosol container laboratory was equipped with the following instruments: an Optical Particle Counter of type PCASP-  
100X, a Cloud Condensation Nuclei Counter of type CCN-100, a Condensation Particle Counter of type CPC-3010 and a  
Scanning Mobility Particle Size Spectrometer (SMPS). Furthermore, a Neutral cluster and Air Ion Spectrometer (NAIS) was  
installed on at the bottom of the top platform of the ship. All of these instruments will be described in further detail below.  
335 Operation of different types of instruments covering overlapping, or often the same, particle size ranges offers a measure of  
mutual quality control on the measurements.

### 3.8.1 Optical Particle Counter

The abundance of particles in the size range  $0.1\text{--}3.0\ \mu\text{m}$  was measured with a Passive Cavity Aerosol Spectrometer Probe  
(PCASP-100X; Droplet Measurement Technologies). The PCASP and Scanning Mobility Particle Size Spectrometer (SMPS,  
340 see Sect. 3.8.4) are both spectral particle counters which provide the partial number concentration at given sizes, i.e. the number  
of particles observed within various sub-ranges over the total range of observable sizes. PCASP measures size according to the  
optical diameter (i.e. how it refracts and scatters light). The advantage of the PCASP is that it can record data quickly (1 Hz),  
while the SMPS instrument is slow. However, the disadvantage of the PCASP is that it can only measure particles larger than  
100 nm.

345 The PCASP instrument recorded the number of observed particles in 30 particle size bins at a frequency of 1 Hz. While the  
PCASP measurement frequency is high, it is generally beneficial to integrate the PCASP over a period as long as 5 minutes to  
get better counting statistics and decrease the relative measurement uncertainty. As a result, the measurements in each size bin  
were block-averaged into 5 minute intervals in a post-processing stage. Between 9 February and 21 March 2018, there were  
a total of 12,000 5 minute intervals, throughout which the instrument recorded for a total of 11,400 intervals. Four additional  
350 measures of quality control were implemented in the data post-processing chain, viz:

1. Using the mole fraction of  $\text{CO}_2$  in a coincident sampling line, measured by the Picarro instrument, to screen the 1 Hz  
sub-samples for contamination by ship exhaust (Hartery et al., 2020). For 11,118 of the 5 minute intervals with data, the  
mole fraction of  $\text{CO}_2$  was less than 405 ppm and the sample was flagged as "clean air".
2. Using the relative wind direction measured by the sonic anemometers in a simple wind sector analysis. Measurements  
355 that were taken when the relative wind direction from both the port and starboard anemometers were within  $60^\circ$  of  
aftward were removed. All other samples were flagged as having come from a "clean sector". Out of the 11,118 clean  
air samples (i.e. not contaminated by ship exhaust) 9,986 were from clean sectors.
3. Calculating the standard deviation of the 1 Hz sub-samples within each of the 5 minute intervals (Hartery et al., 2020).  
Even for a steady concentration of particles, the number of particles counted within a given interval will vary according  
360 to Poisson counting statistics; thus, the standard deviation of the 1 Hz samples within the 5 minute interval should be  
approximately equal to the square root of the measured concentration. However, if the standard deviation of the 1 Hz



sub-samples was more than three times greater than the square root of the concentration, then the 5 minute sample was discarded. This additional measure removed 184 samples.

365 4. Removing observations in the first size bin, as the lower threshold of particle detection in this bin is not well defined due to potential variations in the refractive index of the measured particle(s). Additionally, the 4<sup>th</sup> and 5<sup>th</sup> size bins were added together and redefined as a single bin, as the 5<sup>th</sup> size bin was in between linear gain stages of the particle counter, which led to spuriously low counts.

370 Overall, 81.7 % of the measurements taken remained after the post-processing described above. This is a reasonable data retention rate, considering the challenges of sampling just ~10 m ahead of the mid-ships exhaust. After post-processing of the measurements, the processed particle size spectra were corrected to ambient conditions by applying size-dependent particle loss corrections which are described in detail in Hartery et al. (2020). Finally, the total particle concentrations in each size bin were normalized by the logarithm of the bin's width.

### 3.8.2 Cloud Condensation Nuclei Counter

375 The concentration of individual particles that can form into cloud droplets, i.e. cloud condensation nuclei (CCN), was measured at varying water vapour supersaturations with a CCN counter (CCN-100; Droplet Measurement Technologies). The CCN and Condensation Particle Counter (see Sect. 3.8.3) instruments are integrating particle counters, which provide the total concentration over a given size range. For a CCN-100 counter, the lower size threshold of observable particles is dependent on the chamber supersaturation and the hygroscopicity of aerosol. The benefit of the CCN-100 is that it provides a measure of the number of "cloud-relevant" particles.

380 Prior to being sampled by the CCN-100, particles were dried with a diffusion drier. The raw CCN-100 observations were recorded at 1 Hz. The instrument observed the total abundance of activated particles for water vapour supersaturations between 0.2–1.0 % at intervals of 0.1 %. Each interval was observed for three minutes, resulting in 1 scan every 30 minutes. Measurements within each supersaturation interval were only retained if the instrument was in thermal equilibrium. The raw, 1 Hz data were averaged into the 3 minute intervals for which supersaturation was constant, screened for contamination by ship exhaust according to the coincident CO<sub>2</sub> mole fraction, the relative wind direction, and the standard deviation of the 1 Hz subsamples. 385 Finally, all of the screened observations at thermal equilibrium were merged to a common hourly date coordinate. As with the PCASP-100X, measurement uncertainties are proportional to the square root of the observed concentration.

The CCN-100 was calibrated by the manufacturer prior to the voyage and calibrated by the operator after the voyage. The calibration procedure followed the methodology described in Rose et al. (2008). Overall, the supersaturation of each stage was 390 accurate to within 20 % of the set-value, e.g. the stated supersaturation of 0.3 % was accurate to within ±0.06 %.

### 3.8.3 Condensation Particle Counter

The total abundance of particles in the size range 0.01–3.0 μm was measured with a Condensation Particle Counter (CPC3010; TSI) at a frequency of 1 Hz. Similar to the data processing procedure for the PCASP-100X, the raw data were screened for





contamination by ship exhaust according to the coincident CO<sub>2</sub> mole fraction, the relative wind direction, and the standard  
395 deviation of the 1 Hz subsamples. The screened data were then averaged over 5 minute intervals and merged to the common  
date coordinate. On 1 March 2018, the laser beam dump became partially dislodged within the optical cavity of the CPC3010  
and the operator was unable to resolve this issue at sea. As this led to spurious counts, the data following 1 March were  
excluded from the data set.

### 3.8.4 Scanning Mobility Particle Size Spectrometer

400 The abundance of particles in the size range 0.020–0.50 μm was measured with a Scanning Mobility Particle Size Spectrometer  
(SMPS3936; TSI). The SMPS instrument sizes particles according to how mobile the particle is in air. The instrument measured  
the total abundance of particles passing through an electrostatic classifier (EC3080L; TSI) with a condensation particle counter  
(CPC3772; TSI). For a specific voltage setting, only particles of a specific size and charge will pass through the EC3080L  
and be observed by the CPC3772. The instrument was set to observe the concentrations of particles at 32 logarithmically-  
405 spaced voltage levels. The concentration at each voltage level was observed over a period of 10 s, with an additional 2 s purge  
between voltages. The instrument scanned through the 32 set voltages once every 6.4 minutes. As with previous counters,  
the coincident CO<sub>2</sub> mole fraction time series was used to screen the raw 0.1 Hz data for contamination by ship exhaust. After  
screening, the concentration-voltage spectra were merged to a common 30 minute data coordinate. The inversion of the merged  
concentration-voltage spectra into concentration-diameter spectra was calculated in the post-processing stage, accounting for  
410 multiple-charged particles and diffusional losses to the bipolar diffusion charger within the SMPS (Stolzenburg, 1988). As with  
the PCASP-100X data, the processed particle size spectra were corrected to ambient conditions by applying the size-dependent  
loss corrections detailed in Hartery et al. (2020).

### 3.8.5 Neutral cluster and Air Ion Spectrometer - NAIS

To detect the distribution of ions (charged particles and cluster ions) in the electric mobility range from 0.0013–3.2 cm<sup>2</sup> V<sup>-1</sup> s<sup>-1</sup>  
415 and the distribution of aerosol particles in the size range from 2–42 nm, a Neutral cluster and Air Ion Spectrometer (NAIS,  
Airel Ltd., Mirme and Mirme, 2013) was deployed on the ship. The measurements are taken with a temporal resolution of  
1.5 minutes. The instrument was installed at the bottom of the mast located on the Tangaroa monkey island (Fig. 3), with the  
inlet facing the port side of the ship. The NAIS has two identical cylindrical Differential Mobility Analyzers (DMA) for the  
simultaneous measurement of positive and negative ions. Each analyser has a sample flow rate of 30 L min<sup>-1</sup> and a sheath  
420 flow rate of 60 L min<sup>-1</sup>. Such high flow rates are used to avoid diffusion losses and ensure significant signal to noise ratio,  
even when ion concentrations are low. The inner cylinder of each analyser is divided into four isolated parts, which keep a  
constant voltage during a measurement cycle. The outer cylinder is divided into 21 isolated rings connected to 21 electrome-  
ters. Naturally charged particles are moved by a radial electric field from the inner cylinder of the DMA to the outer cylinder.  
The current carried by the ions is further amplified and measured with electrometers. These data are converted first into elec-  
425 trical mobility and further into the size distribution of ions. For detection of neutral particles, particles are charged by ions  
originating from a corona discharge to an equilibrium that is used to calculate the total particle concentration in a given size



range. The size of ions generated by the corona discharge is around 2 nm, masking the atmospheric signal of this size of neutral clusters. In addition to ion and particle measurements, each measurement cycle contains an offset measurement during which particles in the sample air are charged by a unipolar corona charger and electrically filtered for measuring the background level of the electrometers. The offset is used to evaluate noise levels and instrument functioning. Measures of quality control were implemented in that data post-processing chain. First, the mole fraction of CO<sub>2</sub> in a coincident sampling line, measured by the Picarro instrument, was used to screen the NAIS data according to the suggested filtering protocol outlined in Sect. 4.2.1. Note that the filtering of the NAIS data differ from the filtering of pollution events for the PCASP and SMPS data, but the impact on the remaining measurements is negligible. Secondly, data above 15 nm were excluded from the final data set due to technical issues with one of the electrometers. Further quality control of the measurements was performed by following the data cleaning and quality check guidelines described in Manninen et al. (2016), which are mainly based on visually inspecting the measurements. Overall, 37 % of the measurements made were included in the QA/QC data set.

In this paper, we only present the particle measurements, and only the particle measurements are included in the data set (see Table A1), excluding the ions as they will be described and discussed in a different publication.

### 3.9 Filter sampler

Ice nucleating particles were collected onto pre-cleaned, 0.2 µm pore diameter Nuclepore polycarbonate membrane filters, each overlying a 3 µm pore diameter clean support Nuclepore membrane, in open-faced filter holders (McCluskey et al., 2018). The filter sampler was placed in front of the bridge about 15 m ASL, at a position relatively clear of sea-spray generated by the ship hull and relatively free from contamination (e.g. ship exhaust), and connected via vacuum tubing to a pump inside the sub-bridge mezzanine space. Twenty one filter samples were obtained between latitudes 41° to 73° S, with sample collection periods ranging from 13.5 to 50 hours, at an average flow rate of 14 L min<sup>-1</sup>. The total volume sampled during each collection was recorded using a gas meter placed after the pump. Samples were stored and shipped frozen to the Colorado State University (CSU) for measurement. Three blank filters were collected and used to adjust for background INPs.

Temperature spectra of INP concentrations active via immersion freezing were obtained with the CSU ice spectrometer (IS) (Hiranuma et al., 2015; McCluskey et al., 2018). Filters were placed into sterile 50 mL polypropylene centrifuge tubes, 5 mL of 0.1 µm filtered deionized water added and particles re-suspended by tumbling end-over-end. Next, 50 µL aliquots (typically 64) of suspensions, and 15-fold dilutions of the suspensions, were dispensed into sterile, 96-well polypropylene trays and the trays placed into the cooling blocks of the IS. Blocks were cooled at 0.33° C min<sup>-1</sup> and the freezing of wells recorded with a CCD camera system. The lower limit of measurement was typically -28° C, with the upper limit defined by sampling statistics. The number of frozen wells at each temperature were converted to the number of INPs mL<sup>-1</sup> of suspension using Eq. 13 in Vali (1971) and this was converted to INPs L<sup>-1</sup> air at ambient conditions using the total volume filtered. Ninety five percent confidence intervals were obtained by applying Eq. 2 in Agresti and Coull (1998).



### 3.10 Dimethyl sulfide (DMS) and carbonyl sulfide (OCS) measurements

#### 3.10.1 Gas chromatograph – GC–SCD

460 Underway continuous measurements of dissolved dimethyl sulfide (DMS) were made using a gas chromatograph (GC–SCD; Walker et al., 2016). The instrumentation consists of a custom built automated preconcentrator (semi-automated purge and trap system), which is coupled to an Agilent Technology 6850 gas chromatograph (GC) with an Agilent 355 sulfur chemi-luminescent detector (SCD). The equipment was set up on the shelter deck of the ship in the “aerosol container” which had a constant surface seawater supply from a depth of about 5 m. For the dissolved DMS measurements, surface seawater was  
465 sampled continuously each day from approximately 08:00 to 21:00, with a 1 hour interruption when water samples taken by the CTD (conductivity, temperature and depth sensor) rosette water sampler were analysed around mid-day. During the voyage, 96 discrete samples were collected using CTD Niskin bottles, where water samples were collected from four to six discrete depths in the layer between 10 and 100 m. These discrete seawater samples provide a means to derive DMS profiles throughout the 100 m ocean surface layer.

470 To avoid contamination, seawater samples were gently filtered by pumping the water, using a peristaltic pump, through a 25 mm GF/F filter. The filter was changed after every four injections. A calibrated volume of 5.84 mL of the filtered water was transferred to a silanized glass chamber, which was fitted with a quartz frit and purged with zero-grade nitrogen (99.9 % pure). To prevent organic matter build-up the chamber and frit were cleaned daily. The gas–phase DMS sample was then dried by passing through Nafion® dryers and trapped on a teflon-lined Tenax® stainless steel trap at  $-20\text{ }^{\circ}\text{C}$  for 5 minutes  
475 and purged at  $110\text{ }^{\circ}\text{C}$  for GC analysis (DB-megabore sulfur column, 70 m length, 0.530 megabore diameter and film thickness  $4.30\text{ }\mu\text{m}$ ). The detector sensitivity was checked daily using two temperature controlled VICI® permeation tubes, one filled with methylethylsulfide (MES) and the other with DMS. MES was used as an internal standard, with samples doped during analysis to allow for correction of short-term changes in detector sensitivity, while the DMS permeation tube provided the external standard (Walker et al., 2016). On average over the duration of the voyage, the detection limit was  $0.079 (\pm 0.016)\text{ pgSs}^{-1}$ .

480 To establish the detector response to sulfur, a calibration curve (instrumental signal versus concentration) was generated using solutions prepared from pure hydrolysed dimethylsulfoniopropionate (DMSP). The calibration curve was used to determine the concentration in an unknown sample by comparison with a set of standard samples of known concentration. Here, DMSP was diluted to produce six different standard solutions ranging between  $0.1$  and  $9.54\text{ nmol L}^{-1}$  in 20 mL gas-tight glass vials. Two pellets of sodium hydroxide (NaOH) were added to each vial to hydrolyse the DMSP to DMS before sealing the  
485 vials with aluminium caps. The standard solutions were then treated the same way as the samples by injection into the stripping system. The relationship between the standard concentrations and the instrument response was then used to determine the concentration of DMS measured in the samples taken during the voyage.

Overall, the quality of the DMS measurements is very good. The data quality procedure that was implemented only removed six data points from the whole data set obtained during the voyage.

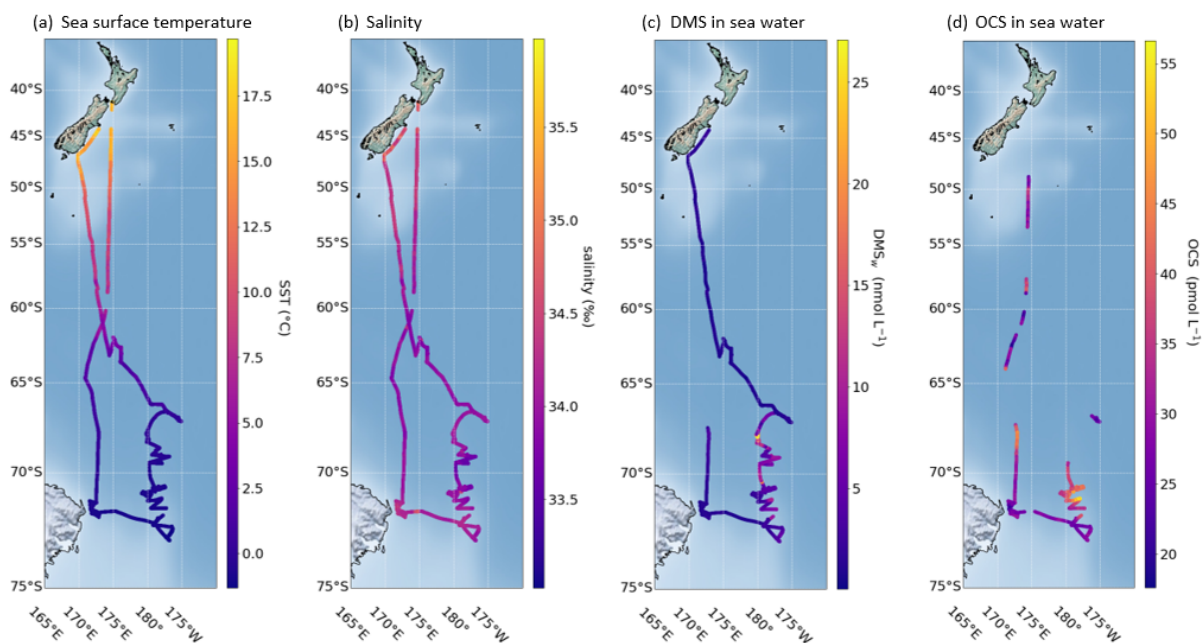


### 490 3.10.2 Mid-Infrared CAvity enhanced spectrometer – MICA

The MICA (Mid-Infrared CAvity enhanced spectrometer, which is a prototype of a commercially available ABB Los Gatos OCS Analyzer) instrument measures carbonyl sulfide (OCS), carbon monoxide (CO) and CO<sub>2</sub> employing Off Axis Integrated Cavity Output Spectroscopy (OA-ICOS, Baer et al., 2002; O’Keefe et al., 1999; Paul et al., 2001). Air samples are internally pumped through a 305 mm long and 51 mm diameter cavity at a mass flow rate of about  $6 \times 10^{-6} \text{ kg s}^{-1}$  with the cavity  
495 pressure regulated to 80 hPa. The beam of a quantum cascade laser (QCL) ramped over the wavenumber range 2050.2–2051.2  $\text{cm}^{-1}$  is coupled into the cavity, the light exiting the cavity on the opposite side is collimated onto a HgCdTe photodiode. Two highly reflective dielectric cavity mirrors allow for an effective path length of approximately 1000 m. Trace gas mixing ratios are retrieved from infrared spectra online using manufacturer Los Gatos software. In addition, raw spectra are saved every 15 seconds to allow for consistency and quality checks of the recorded data.

500 For the TAN1802 voyage, MICA was deployed in the temperature controlled aerosol container laboratory, alternating measurements of the marine boundary layer and the surface ocean at intervals of 10 minutes for air and 50 minutes for water using a fully autonomous setup that consists of a pump, switching valves and a spray-head seawater equilibrator (Lennartz et al., 2017). The intake of the airline was located at 20 m ASL at the starboard forward mast on the monkey island (Fig. 3). Seawater from about 5 m depth was supplied to the equilibrator at a flow rate of 2-3  $\text{dm}^3 \text{ min}^{-1}$ . To ensure that concentrations remain at  
505 near equilibrium, the gas phase was constantly recirculated between the equilibrator headspace and MICA. A filter (PallAcro, 0.7  $\mu\text{m}$ ) was placed directly in front of the MICA inlet to remove particles and droplets. Teflon was used for all tubing, and materials known to cause OCS contamination such as rubber, were avoided. From gas phase mixing ratios in the equilibrated air, dissolved concentrations were calculated using Henry’s law constants.

MICA was calibrated in the laboratory before and after the TAN1802 voyage, to ensure data quality, determine measure-  
510 ment accuracy and precision, and cross check correction functions accounting for some known non-linearities at low and high concentrations. OCS mixing ratios ranging from 0.25–5 ppb were prepared using permeation devices. In addition, a NOAA certified standard containing 450 ppt OCS was used to ensure consistency with data from OCS sampling networks. Instrument response was consistent for all standards with accuracy better than 30 ppt for mixing ratios below 750 ppt and 4 % for higher mixing ratios, translating to about 2  $\text{pmol dm}^{-3}$  for dissolved concentrations. Precision was determined by sampling  
515 the NOAA standard as 90 ppt at the nominal 1 Hz sampling rate and 15 ppt (about 1 pM) with 2 minute averaging, with no significant drifts observed at longer time scales over a 4 hour sampling period. CO mixing ratios in the range 10–2500 ppb and CO<sub>2</sub> mixing ratios in the range 10–2500 ppm were prepared from a  $5 \pm 0.05 \text{ ppm CO}$  and  $5000 \pm 2.5 \text{ ppm CO}_2$  standard (Air Products) by dilution with clean Argon gas (containing no detectable CO and CO<sub>2</sub>). Taking into account uncertainties of the standard and the dilution system, respective accuracies for CO and CO<sub>2</sub> are derived to be 10 ppb and 6 ppm, corresponding to  
520 0.01  $\text{nmol dm}^{-3}$  and 0.1  $\mu\text{mol dm}^{-3}$  for dissolved concentrations, respectively. During the 4 hour experiment with the NOAA standard, which also contains CO and CO<sub>2</sub>, a 1 Hz precision of 5 ppb for CO and 1 ppm for CO<sub>2</sub> was determined. This reduces to 1 ppb and 0.2 ppm respectively at the 2 minute temporal resolution at which MICA data for TAN1802 are provided. Pre-



**Figure 4.** The track of the R/V Tangaroa during the Southern Ocean Ross Sea Marine Ecosystem and Environment voyage (a) sea surface temperature, (b) salinity, (c) DMS measured in seawater, and (d) OCS measured in seawater. The measurements of DMS and OCS together with derived sea-air fluxes will be discussed in more detail in Sect. 4.3.1 and 4.3.2.

and post-campaign calibrations for all gases were in excellent agreement. Raw IR spectra recorded during the cruise were inconspicuous and consistent with the mixing ratio data retrieved online.

## 525 4 Data sets

### 4.1 Meteorological observations

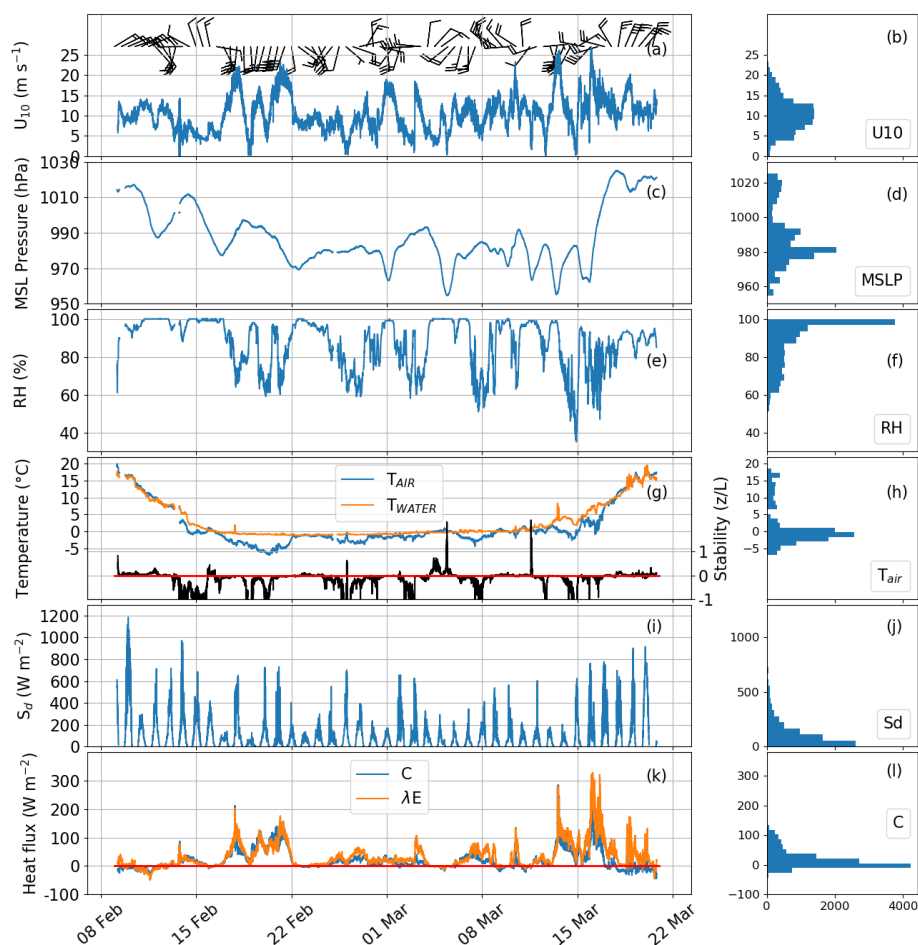
Favourable meteorological conditions were encountered for much of the voyage with the entire study area (south of 60° S, hereafter referred to as the Southern Ocean) being free of sea-ice for the duration of the voyage. The ship faced a strong head wind (southerly) on the transect from 60° to 70° S. Overall, only three periods of enforced down-time occurred. The ship track together with sea surface temperature and underway sea surface salinity encountered during the voyage are shown in Fig. 4. When reaching the Southern Ocean, the presence of sharp gradients in sea surface temperature (drop from >5 °C to about 0 °C) in proximity to the Antarctic Circumpolar Current (ACC) fronts is evident in the data. Salinity decreased from greater than 34.5 to 34 ‰ or less within the Southern Ocean, but increased close to the ice edge (to maximum of 35.9 ‰).

Time series of observed wind speed, pressure, relative humidity, temperature, sea surface temperature, and radiation along the complete voyage track are shown in Fig. 5. The vessel reached the Southern Ocean region on day five of the voyage

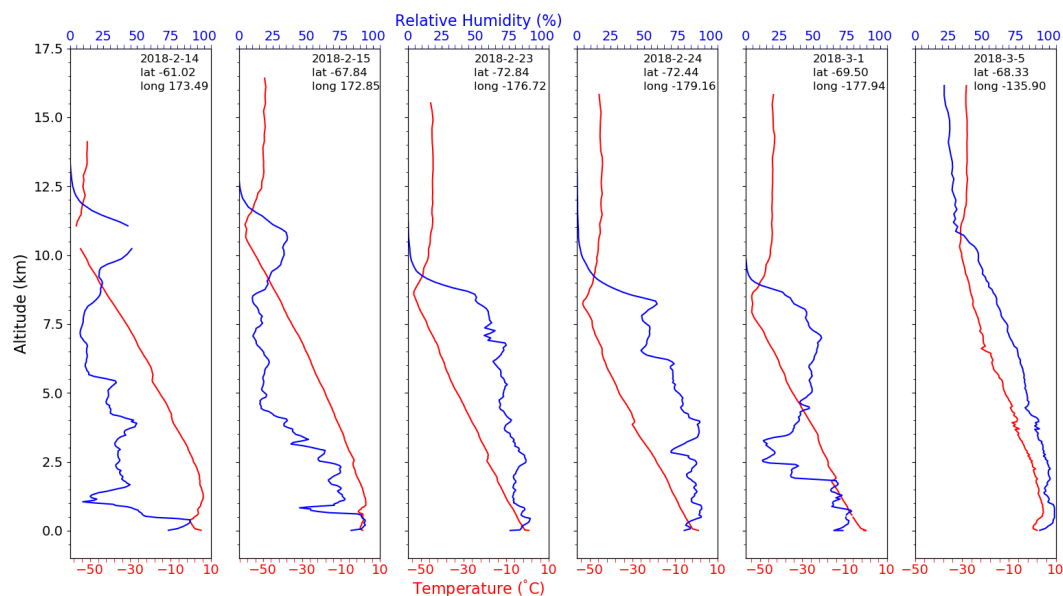


(14 February 2018). The drop in air temperature and pressure when entering the Southern Ocean is clearly visible in Fig. 5(c, g). Over the Southern Ocean, air temperatures observed ranged mainly between +1 °C and -2 °C with a minimum of -7 °C (Fig. 5), with observed sea surface temperatures remaining around 0 °C. The median air and sea surface temperatures throughout the time spent in the Southern Ocean were -1.4 °C and -0.3 °C, respectively. The observed median wind speed at 10 m in the Southern Ocean was 9 m s<sup>-1</sup> (interquartile range of 5.96), and the maximum wind speed at 10 m recorded in the Southern Ocean was 26 m s<sup>-1</sup>. The wind direction over the Southern Ocean corresponding to strong winds was mostly south and south/west as indicated by the wind barbs in Fig. 5(a). The southernmost latitude reached during the voyage was 73° S.

Figure 6 shows example temperature and relative humidity profiles between the ground and 17.5 km as measured by radiosondes, which were released south of 60° S. Fog events associated with moist air trapped near the surface by low-level temperature inversions are visible on 15 February and 5 March 2018 in the radiosonde data. The tropopause is also clearly visible in the temperature profiles at around 11 km (15 February), dropping to between 8 and 8.5 km further south. Above the pronounced tropopause lies the stable and dry stratosphere with temperatures around -50 °C.



**Figure 5.** Summary of the meteorological conditions during TAN1802, showing (a) 12 hourly vector-averaged wind barbs for measured wind speed (barbs are in knots, 1 barb = 10 knots) together with the wind speed at 10 m ( $u_{10}$ ), (c) mean sea level pressure (MSLP), (e) relative humidity (RH), (g) air temperature ( $T_{air}$ ), sea surface temperature ( $T_{water}$ ), and the Monin-Obukhov stability parameter ( $z/L$ ) (black line), where  $z$  is the height of wind measurement and  $L$  is the Obukhov length scale (m); with positive and negative values indicating stable and unstable conditions in the lower atmosphere, respectively, (i) short wave radiation ( $S_d$ ), and (k) sensible ( $C$ ) and latent ( $\lambda E$ ) heat flux. Small panels on the right show the corresponding histograms for 5 minute resolution derived from all AWS measurements that were made during the voyage. The ship entered the Southern Ocean (region south of  $60^\circ S$ ) on 14 February and leaving this region on 16 March 2018.

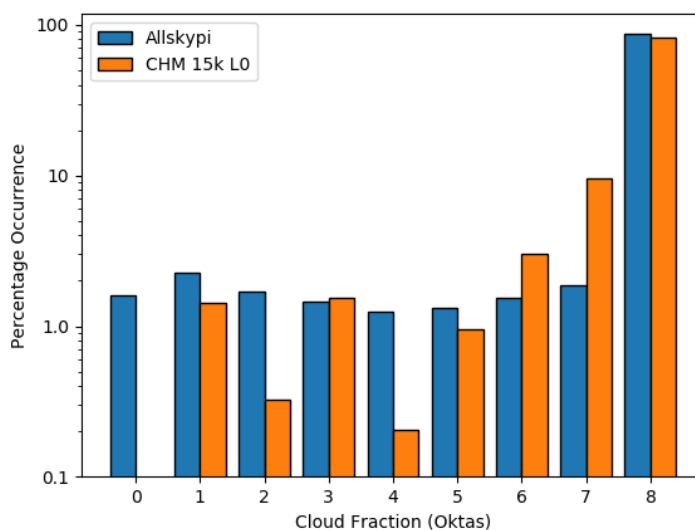


**Figure 6.** Example temperature and relative humidity profiles measured by the weather balloon radiosondes released during the voyage.

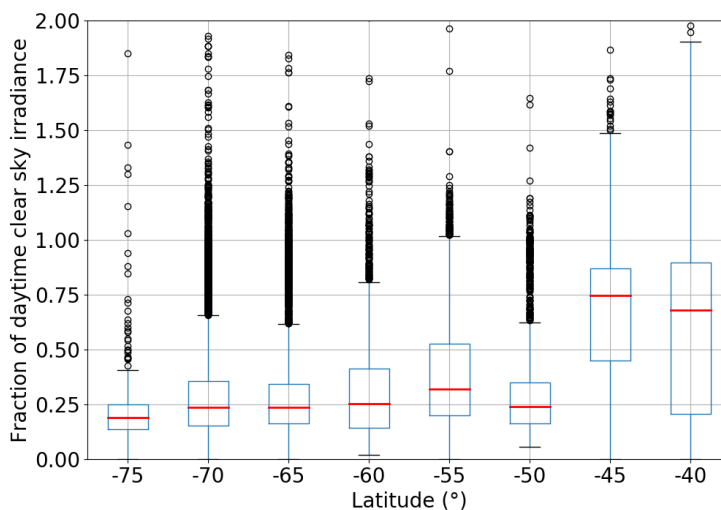
### Clouds and precipitation

Observations of clouds were made throughout the voyage, with observations dominated by low-level cloud base heights and high cloud fraction, consistent with previous observations in the Southern Hemisphere (Protat et al., 2017; Klekociuk et al., 2020). Synoptic weather observations, complemented by all-sky cameras, were performed throughout the voyage and revealed that the most frequently observed cloud types were stratus (52%), stratocumulus (30%), and nimbostratus (23%). The cloud fraction was derived by the allskypi system for solar zenith angles of less than  $90^\circ$  with the mean over the voyage from south of  $60^\circ$  S being 0.92%, with no single day averaging less than 0.79%. Cloud fraction obtained from the ceilometer measurements (level 0 data product) compare well to the cloud fraction from the all-sky camera system with a mean of 0.95 for all measurements made south of  $60^\circ$  S. The occurrence of cloud fraction, in oktas, from allskypi and from the ceilometer is shown in Fig. 7.





**Figure 7.** Cloud fraction derived from allskypi and the ceilometer (level 0 output), expressed in oktas, i.e. number of eighths of sky covered by cloud.



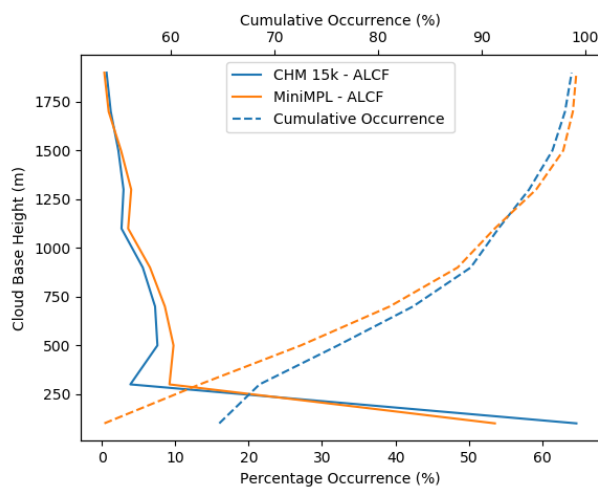
**Figure 8.** Box plot showing the upper to lower quartiles of the ratio of downwelling shortwave solar radiation ( $S_d$  in  $W\ m^{-2}$ ) received by the Eppley Precision Spectral Pyranometers to the theoretical clear sky value calculated for an atmospheric transmission coefficient of 0.86, on a minute by minute basis throughout the voyage and categorised centred on  $5^\circ$  latitude bands (e.g.  $-40^\circ$  category ranges from  $-42.5^\circ$  to  $-37.5^\circ$ ).



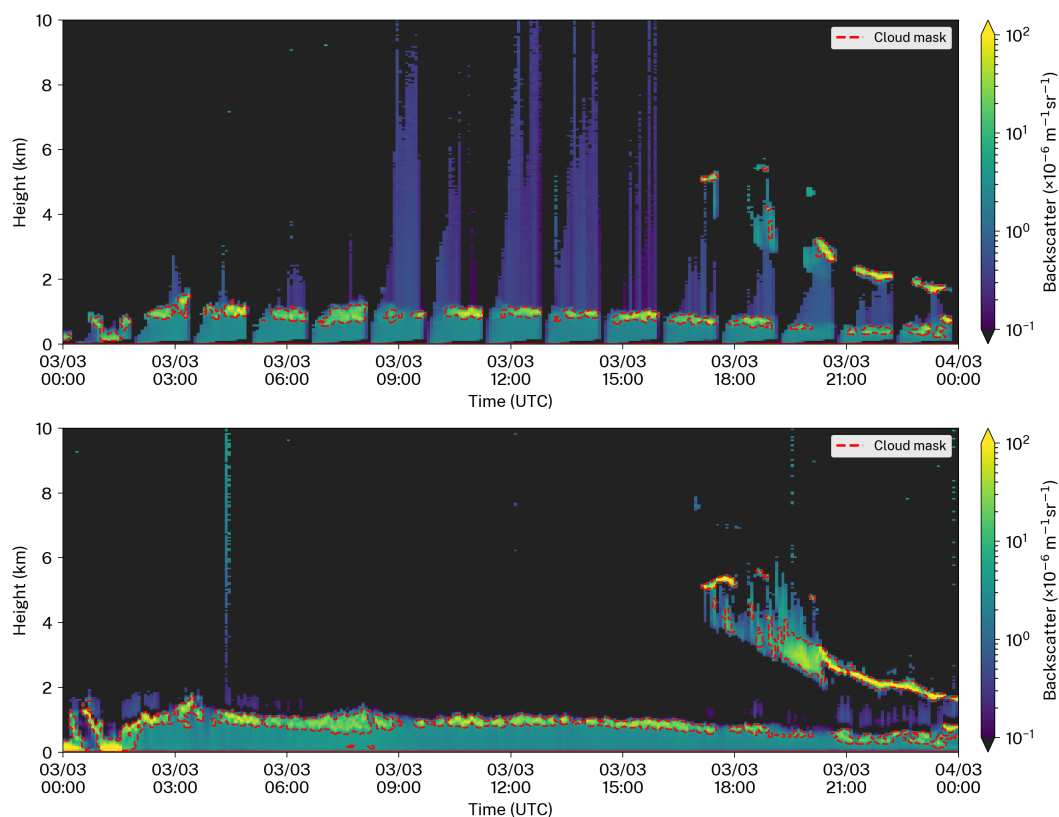
Cloud observations are dominated by periods of complete cloud cover. In such cases, the all-sky camera and the ceilometer agree well with each other due to the lack of spatial variability (Fig. 7). When lower cloud fractions are observed and when there is spatial variability, the agreement between the ceilometer derived cloud fractions and the camera is reduced compared to events with complete cloud cover. This is due to the limited area that the ceilometer uses to compute cloud fraction compared to the camera system. The former uses a time weighted average of cloud occurrence to infer the spatial cloud fraction, essentially assuming that the spatial variability at a given moment is equivalent to the temporal variability over the preceding period. Furthermore, the difference can be also caused, in part, by the different geographical region sampled by the ceilometer and a sky camera (directly at zenith versus all-sky).

The on-board Eppley pyranometers were used to examine the impact of the high cloud fraction on the received solar radiation (Sd) compared to the expected clear-sky value at the location of the vessel. The downwelling shortwave radiation measured during the voyage is shown in Fig. 8, indicating a reduction in radiation received at the surface due to the high prevalence of clouds (see Fig. 7) south of 50° S, with median radiation received at the surface being only around a quarter of the anticipated clear sky value.

Using the cloud base height product derived from both the ceilometer and MiniMPL raw data using the ALCF tool (Kuma et al., 2020), it is possible to look at the frequency of cloud occurrence binned by height as shown in Fig. 9. The observations clearly indicate that for the majority of the campaign period there was a high abundance of low-level clouds, with over 95 % of the cloud base heights occurring at or below 1250 m and peaking below 250 m.



**Figure 9.** Cloud base height derived from the ceilometer and MiniMPL data processed using the ALCF software. The bottom axis shows the percentage occurrence of clouds binned by height (solid lines) and the top axes show the cumulative occurrence binned by height (dashed lines). Note that the near-surface fraction can be affected by the incomplete overlap of the lidar in the first few hundred metres.



**Figure 10.** Automatically generated output plots from the ALCF tool showing backscatter ratios over 24 hours for 3 March 2018 for the MiniMPL data (upper panel) and ceilometer data (lower panel). Cloud mask is overplotted as dashed red lines. The periodic structure in the MiniMPL occurs because it was scanning over a range of elevation angles and so would saturate at lower altitudes when measuring at lower elevations angles (larger air masses occurring closer to horizon).



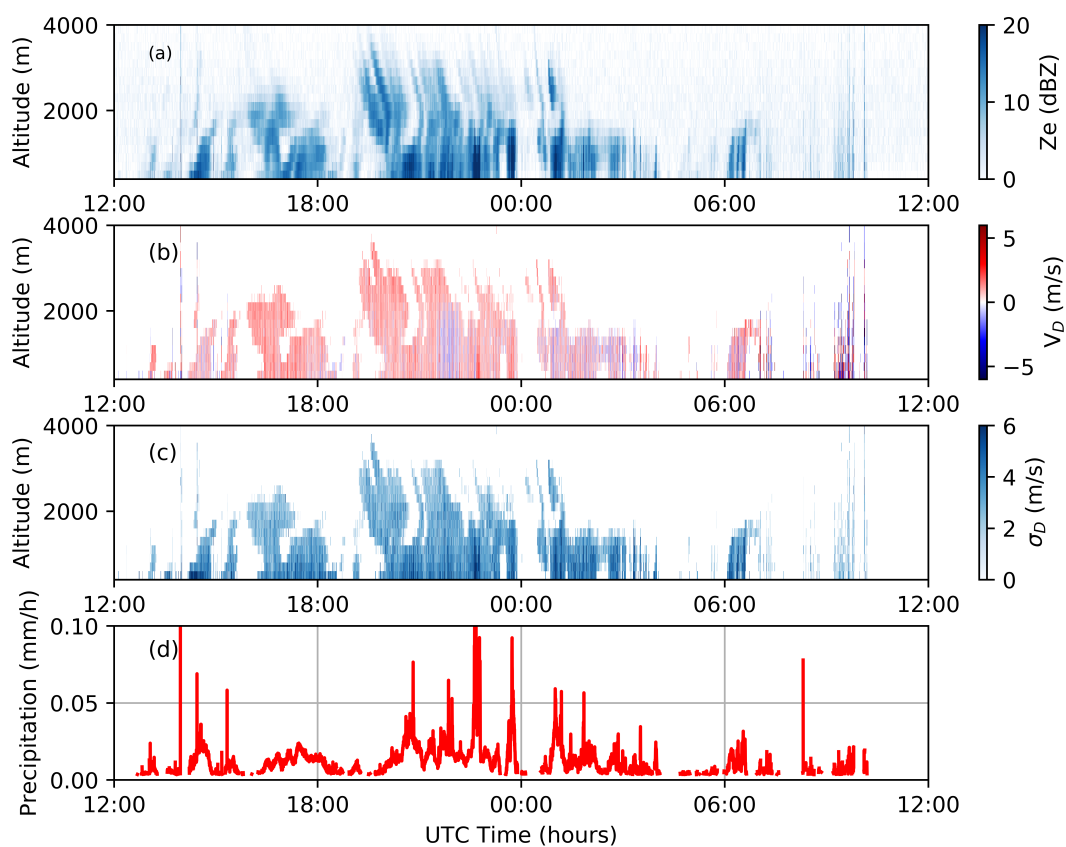
575 An example of the backscatter ratios measured by the two lidar instruments is shown in Fig. 10, wherein we demonstrate the differences in sampling between the two instruments. The MiniMPL was scanning over a range of elevation angles (see Sect. 3.3). The scans at lower elevation angles would saturate at a lower altitude due to the higher effective air mass being measured. Thus the periodic structure observed in the MiniMPL shown in the upper panel of Fig. 10, while the ceilometer, which did not have elevation scanning functionality and only measured in the zenith direction, shows a more continuous time-series.

580 This particular day (3 March 2018), with its nearly unbroken cloud signal around 1 km, is representative of the overall cloud statistics from the voyage. The initial 2 hours (00:00–02:00 UTC) show surface level cloud or fog (Fig. 10). From 02:00 to 18:00 UTC, low level cloud between 1 and 1.5 km is present. At 18:00 UTC, in addition to the low level cloud, a higher cloud layer at 5 km is observed along with probable precipitation as it descends to 2 km by the end of the 24 hour period being shown. A challenge with measurements of this type is that there may also have been other high cloud layers throughout the

585 day but they were not seen through the saturated low level cloud layer.

Precipitation was monitored throughout the voyage, but with relatively low occurrence throughout. Figure 11 displays the radar reflectivity, vertical velocity and spectral width for a range of altitudes over one 24 hour period collected near 71° S derived using the scheme detailed in Maahn and Kollias (2012). Figure 11 also displays snowfall estimates at the surface derived from the MRR-2 data. Note that the corresponding in situ precipitation measurement device on R/V Tangaroa was

590 not sensitive enough to snowfall to measure these very small rates of accumulation. The diagonal structures identified in Fig. 11 between approximately 19:00 UTC on 16 February and 01:00 UTC 17 February 2018 at altitudes above 2 km in the radar reflectivity are related to fall streaks, which represent the movement of precipitation towards the surface. The upward and downward motions observed in Fig. 11(b) are a distinctive characteristic of snowfall.



**Figure 11.** Altitude versus time contour plots of the (a) radar reflectivity, (b) vertical velocity, and (c) Doppler spectral width derived from the MRR-2 Doppler spectra over 24 hours between 16 February 2018 12:00 and 17 February 2018 12:00 UTC derived using the schemes detailed in Maahn and Kollias (2012). The corresponding empirical estimate of surface snowfall is identified in panel (d).



## 4.2 Particle size distributions and cloud condensation nuclei

### 595 4.2.1 CO<sub>2</sub> measurements for identifying contamination events

Throughout the voyage the mole fractions of atmospheric CO<sub>2</sub> were measured continuously by using a Picarro CRDS (Sect. 3.7). While the sampling line of the Picarro was separate to the particulate sampling line, it was in close proximity (within 5 m). Contamination from ship exhaust from the rear of the ship would have been sufficiently well-mixed in the turbulent air around the ship superstructure to affect both sampling lines. The use of CO<sub>2</sub> measurements together with wind speed and direction  
600 measurements are often used as a reliable method to identify periods of contamination in the air sampled by the sampling inlet for all aerosol measurements performed in the aerosol container lab.

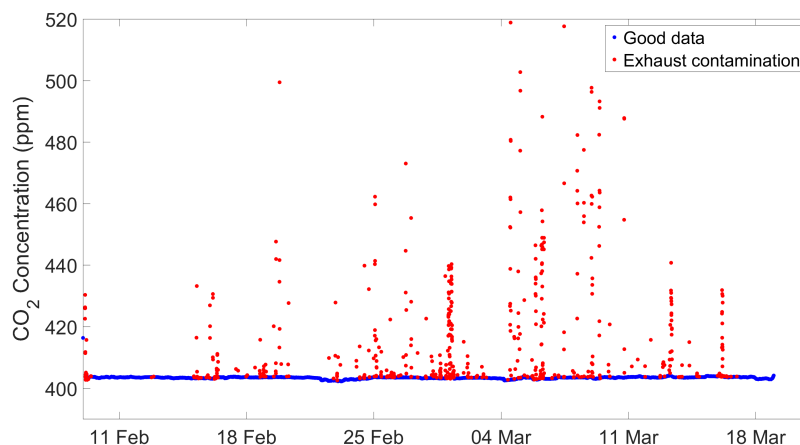
Five minute mean CO<sub>2</sub> measurements for the entire voyage are shown in Fig. 12. Following initially high values at the start of the voyage, due to proximity to land, atmospheric CO<sub>2</sub> concentration rapidly decreased to close to the baseline value of 403 ppm, which was observed at NIWA's Baring Head atmospheric station at the time of the voyage. This baseline value is  
605 consistent with the voyage being conducted within the Southern Ocean/Antarctic source region for air selected for baseline analysis at Baring Head (Brailsford et al., 2012).

A large number of brief episodes of high CO<sub>2</sub> concentration (to >500 ppm) are apparent in the CO<sub>2</sub> data set shown in Fig. 12. These are attributed to contamination from the exhausts of the ship's engine and Dynamic Positioning System (DPS) generators being blown back towards the airline intake above the bridge in certain wind conditions. During the voyage the  
610 DPS was operated during Deep-Towed Imaging System (DTIS) deployments. Two tests were used to identify these exhaust contamination events in the Picarro CO<sub>2</sub> data, i.e. CO<sub>2</sub> measurements were deemed as pollution events if:

1. the CO<sub>2</sub> standard deviation of the 5 minute mean was greater than 0.1 ppm, AND
2. the CO<sub>2</sub> 5 minute mean was more than 0.1 ppm above the calculated 50-point median filter that was applied to the CO<sub>2</sub> 5 minute mean data.

615 In Fig. 12, these exhaust contamination conditions are indicated in red, while data considered as good are indicated in blue. The exhaust contamination tests are effective in identifying all of the data points attributable to exhaust contamination, at the expense of including a small number of points that may be considered good data.

All particle measurements described below were screened according to contamination events using the method described here or in their respective sections above.

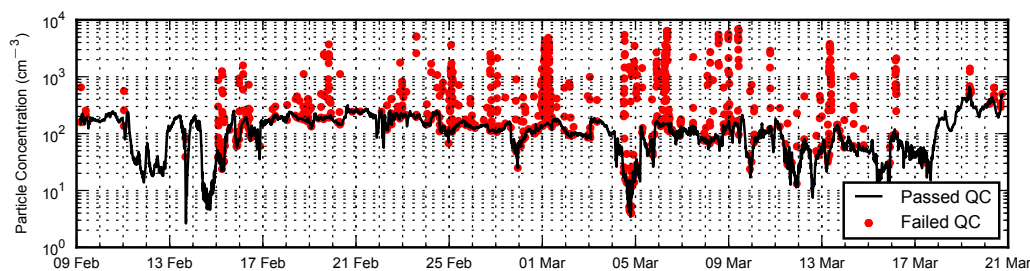


**Figure 12.** Calculated 5 minute mean of atmospheric CO<sub>2</sub> concentration measured by the Picarro. Colour coding indicates quality controlled data representative of baseline air or data points flagged as ship exhaust contamination.

#### 620 4.2.2 Particle size distributions

As described in Sect. 3.8.1, a reasonably rigorous data quality procedure was implemented to screen the continuous aerosol observations for potential contamination by ship exhaust. In Fig. 13 the time series of the total concentration of particles observed by the PCASP-100X is shown. These values represent the concentration of particles in the size range 0.1–3 μm. In Fig. 13, the quality-assured time series is overlaid by the measurements that were removed according to the data quality procedure.

625 Overall, the procedure was highly successful in removing contaminated aerosol observations; however, the procedure also removed a small number of useful observations.



**Figure 13.** Comparison of raw (red) particle concentration and quality-controlled (black) data after a quality procedure to remove potentially contaminated aerosol samples was implemented based on wind direction, the co-incident CO<sub>2</sub> time-series and Poisson counting statistics. This procedure is described in detail in Sect. 3.8.1.



The quality assured measurements from all of the aerosol instruments operated throughout the voyage are shown in Fig. 14a–e. In Fig. 14a, the time series of the PCASP-100X observations is shown. Note that the concentrations in each size range have been normalized by the log width of the size bin. A notable instrument artefact within the PCASP-100X measurements is the persistent local peak in concentrations between 0.5–0.6  $\mu\text{m}$ . Similar to the lack of particles observed in the 5<sup>th</sup> size bin (see Sect. 3.8.1), this is likely a result of gain stitching errors between the multiple linear amplifiers the PCASP uses to detect particles across such a broad range of sizes. The user may choose to exclude this size bin in further analysis.

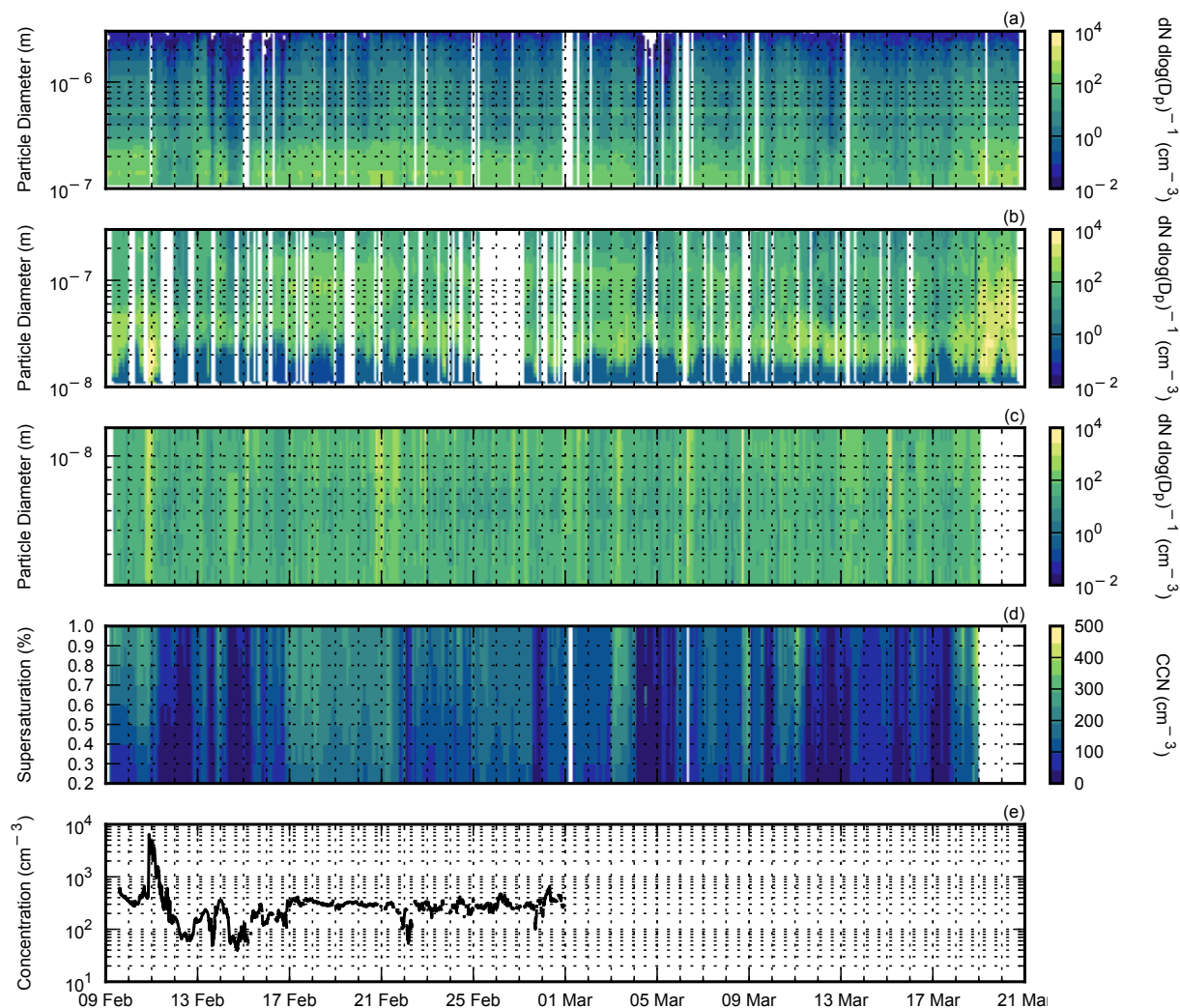
In Fig. 15, the median particle concentration size spectrum measured by the PCASP-100X, SMPS, and NAIS is shown for the whole voyage. This spectrum can be used to compare particle concentration measurements between the various particle counters. Overall, there was reasonably good agreement between the particle size distributions measured by the PCASP-100X and SMPS 3936. However, on average the PCASP reported 1.6 times as many particles in the 100–300 nm range as the SMPS, and it is recommended that the SMPS data are used in this size range.

In Fig. 15, it appears that there is significant disagreement between the SMPS3936 and the NAIS in the 10–15 nm particle size range. However, this is most likely a result of additional deposition of these particles within the sampling conduit and inefficient transmission through the SMPS itself. The NAIS measurements, which were conducted from the mast of the ship, are likely more accurate in this size range. The SMPS data for particles smaller than 20 nm are available, but should be interpreted with caution.

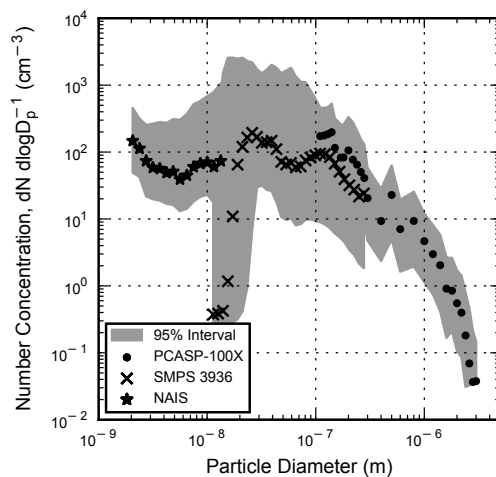
Finally, while a median of all aerosol size distributions was shown in Fig. 15, many different types of air masses were encountered throughout the voyage. In Fig. 16, air mass back trajectories presented in Hartery et al. (2020) were exploited to calculate the fraction of time air masses spent over different geographic regions. These data will help researchers contextualize our observations and enable better cross-comparison with other studies. For instance, on 17 February 2018 there was an abrupt change in the air mass as the vessel arrived at Cape Adare. This resulted in a rapid increase in the number of accumulation mode particles (see Fig. 14a and b).

Overall, we expect these measurements to be of great value to the scientific community as they cover the entire particle size spectrum. Complementary to Hartery et al. (2020), the combination of sub- and super-micron particles can be used to test existing sea spray emissions parameterizations, or derive new ones specially adapted to the Southern Ocean. In particular, the role of biological processes on sea spray emissions and properties for seawater temperatures and phytoplanktonic populations specific to the Southern Ocean can be explored using this data set. Moreover, the combination of these total aerosol size spectra with the cloud condensation nuclei spectra could potentially be used to investigate particle activation within high-latitude, low-level marine stratocumulus. In addition, a new particle formation event was observed on 11 February 2018 as the R/V Tangaroa left the continental shelf. This event is highlighted in Fig. 17 and could be studied in further detail to better understand the conditions which favour new particle formation.

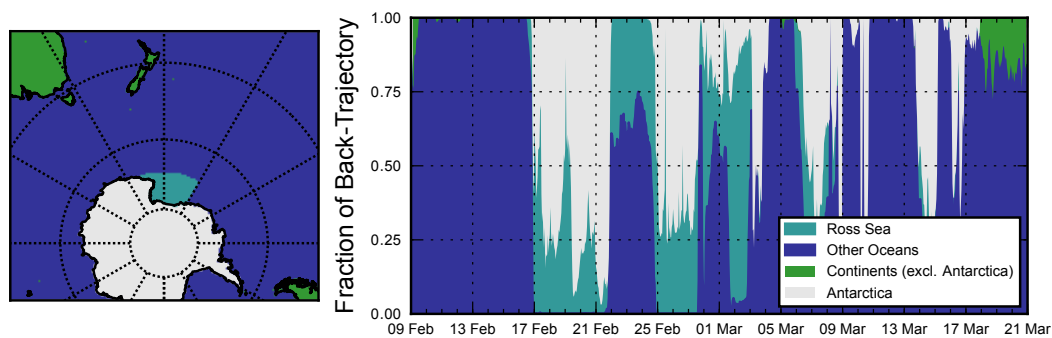




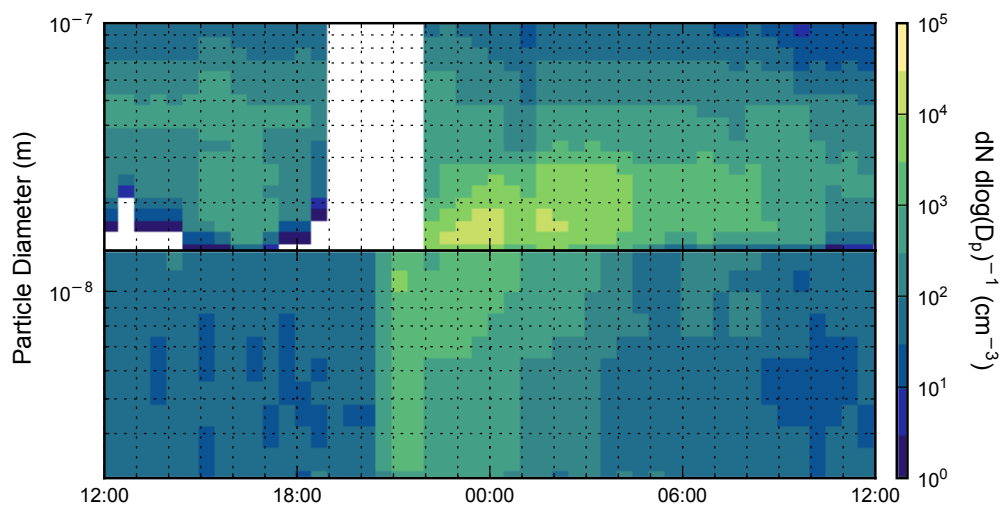
**Figure 14.** Spectral and total particle concentrations measured by various particle counters throughout the Southern Ocean Ross Sea Marine Ecosystems and Environment voyage. Data gaps resulted from intrusions of polluted air into the sampling line or from instrument/system errors. (a) PCASP-100X, (b) SMPS 3936, (c) NAIS, (d) CCN-100, and (d) CPC3010. See Sect. 3.8 for more details.



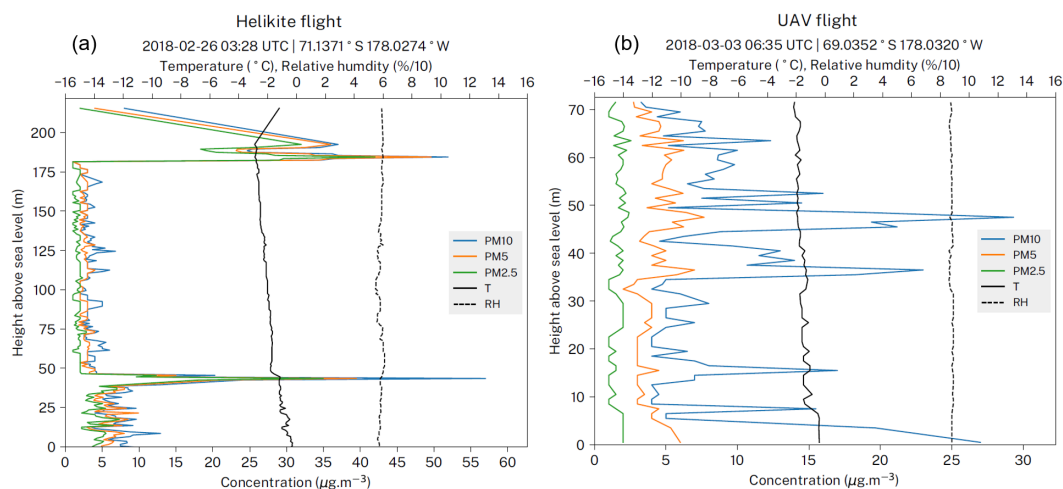
**Figure 15.** The median particle size distribution measured by the PCASP-100X, SMPS 3936, and NAIS across the entire voyage. Note that the spectrum above 3  $\mu\text{m}$  is not shown and was not evaluated in this study.



**Figure 16.** Left: Geographic regions (as indicated by the legend) used for the back-trajectory modelling over the Southern Ocean. Right: The fraction of time air masses spent over different geographic regions in the five days prior to the measurements. The back-trajectory modelling is described in detail in Hartery et al. (2020).



**Figure 17.** Same as Fig. 14(b, c) but for one day only. On 1 February 2018 at approximately 21:00 UTC, a new particle formation event that was detected by the SMPS (top) and NAIS (bottom) spectrometers.



**Figure 18.** In situ boundary layer aerosol concentration, atmospheric temperature and relative humidity in two locations in the Ross Sea sampled with (a) helikite flight and (b) UAV flight. The sampling was performed using an Alphasense OPC-N2 unit connected to a radiosonde which were attached to the aircraft. Shown are the particulate matter (PM) concentration  $PM_{2.5}$ ,  $PM_5$  and  $PM_{10}$ , temperature (T) and relative humidity (RH). Height is based on the GPS coordinates of the radiosonde.

### 4.2.3 $PM_{10}$ , $PM_5$ and $PM_{2.5}$ measurements

On two occasions we sampled in situ boundary layer aerosol concentrations with a UAV and a tethered helikite up to a height of about 70 m and 200 m, respectively (Sect. 3.1.2 and 3.1.3). Particulate matter (PM) concentration, temperature and relative humidity as a function of height measured during these flights are shown in Fig. 18. Background concentration observed were about  $2 \mu\text{g m}^{-3}$  during the UAV flight and  $5 \mu\text{g m}^{-3}$  during the helikite flight, decreasing with height to about  $1 \mu\text{g m}^{-3}$  at 70 m and  $2 \mu\text{g m}^{-3}$  at 175 m on the respective flights. The spikes in  $PM_{10}$  concentration of up to  $25 \mu\text{g m}^{-3}$  and  $50 \mu\text{g m}^{-3}$  in Fig. 18 suggest data contamination by ship exhaust. In particular, the helikite profile is affected by two spikes at about 40 m and above 175 m. Despite this limitation, these measurements are valuable due to the scarcity of airborne in situ aerosol concentration measurements in this region. Only two successful flights were conducted due to adverse weather conditions, which prevented flying the UAV or helikite during most of the voyage.

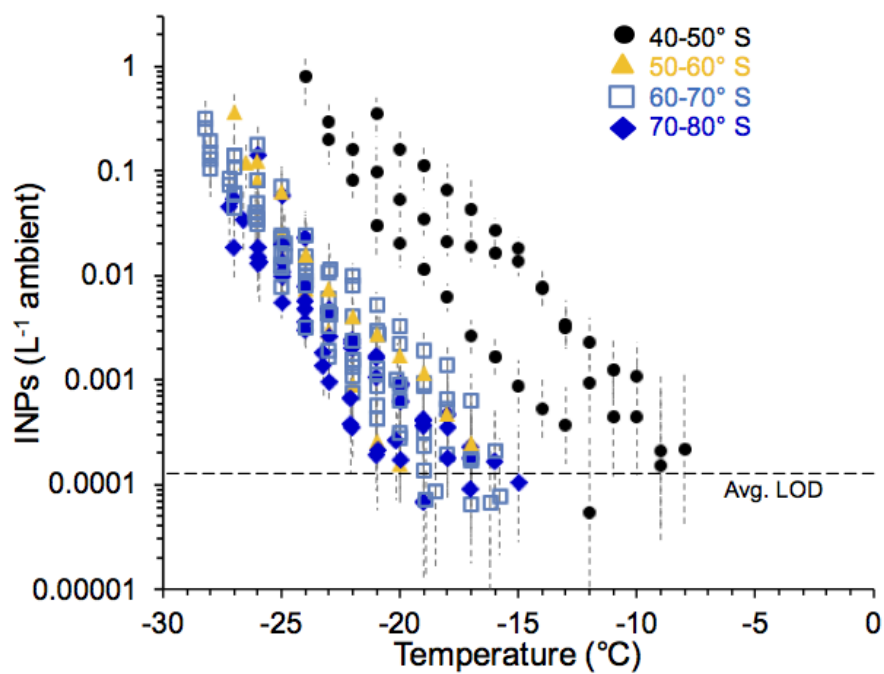
With the flights performed, we demonstrated the use of UAV and helikites to sample the atmosphere and showed that it is possible to use these aircraft for measurements over the Southern Ocean. However, the deployment is limited by strong winds, high swell, and low temperatures, which limit the battery lifetime. Despite that, UAVs and helikites provide useful means to measure aerosol concentration in the boundary layer, which cannot be easily measured with other methods.



#### 4.2.4 Ice nucleating particle concentrations

INP concentrations in four latitude bins measured during the TAN1802 are shown in Fig. 19. South of 50° S, the INP concentrations were consistently low:  $\leq 0.1 \text{ m}^{-3}$  at  $-15^\circ \text{ C}$ , typically  $0.2\text{--}1 \text{ m}^{-3}$  at  $-20^\circ \text{ C}$ , and typically  $5\text{--}25 \text{ m}^{-3}$  at  $-25^\circ \text{ C}$ . These concentrations fall in the lower half of the range measured in samples taken over the same period during voyages of the R/V Aurora Australis from Hobart, Tasmania to the Australian Antarctic Division base at Mawson (Antarctica) and to Macquarie Island (DeMott et al., 2018). Identical sampling and measurement protocols, as applied here, were used for the Aurora Australis samples. The observed INP concentrations are also comparable to those recorded south of Tasmania in March and April 2016 (McCluskey et al., 2018), and to INP concentrations at  $-15^\circ \text{ C}$  from samples taken during TAN1502 in the same general regions as TAN1802 (Welti et al., 2020). Welti et al. (2020) also recorded similarly low INP concentrations at  $-15^\circ \text{ C}$  during the Antarctic Circumnavigation Expedition of 2016–2017. By contrast, the original work of Bigg (1973) found much higher levels, of about  $14 \text{ INPs m}^{-3}$  at  $-15^\circ \text{ C}$ , in the same region of the Southern Ocean as traversed during TAN1802. The lowest INP values were recorded at  $72^\circ \text{ S}$  on the 24–25 February 2018. Using back trajectory calculations, it was found that this low INP concentration corresponds to sampled air that had travelled, over the previous 72 hours, west and north from the coast of west Antarctica, the Ross Sea and the Ross ice shelf. The back trajectories were calculated using the HYbrid Single Particle Lagrangian Integrated Trajectory (HYSPLIT) model applying the Global Data Assimilation System at a grid resolution of  $0.5^\circ$ , and initiating the trajectories at 50 m ASL (not shown).

The three filters taken as the ship cruised between  $40$  and  $50^\circ \text{ S}$  had markedly higher INP concentrations (Fig. 19). However, all had sampled air that had, within a few hours, passed over New Zealand for part or most of the sampling period (results from the HYSPLIT back trajectories). The two highest spectra were from membranes that had filtered terrestrially-influenced air for most of their sampling periods. By contrast, the lowest spectrum was obtained from a filter that had sampled, for only a few hours, air that passed for about 6 hours over the south eastern corner of the North Island, highlighting the influence of even a modest period of exposure of boundary layer air to terrestrial emissions.



**Figure 19.** Cumulative spectra of ice nucleating particle (INP) concentrations in the boundary layer measured during the voyage. The spectra are divided by latitude to highlight the uniformly low INP concentrations south of 50° S and the raised levels in samples taken when the ship was east of New Zealand. LOD stands for limit of detection.



### 4.3 DMS and OCS observations

#### 695 4.3.1 Surface seawater DMS and derived fluxes

Dissolved DMS concentrations in surface seawater as measured during the TAN1802 voyage along the ship track are shown in Fig. 4(c). Throughout the voyage, DMS measurements obtained from the SCD (underway) and the data obtained from the CTD rosette sampler bottles at 10 m (not shown) were in good agreement and DMS profiles obtained from the CTD samples generally showed a near-surface maximum with lowest concentrations at or just below the surface mixed layer. Throughout the majority of the voyage, observed dissolved DMS concentrations in surface water were low between about 0.06 and 2 nmol L<sup>-1</sup>. The highest DMS concentrations were measured in the Eastern Ross Sea, in the transect between Iselin Bank and Scott Island, with a maximum concentration of 27 nmol L<sup>-1</sup> (Fig. 4).

The DMS sea–air flux estimates ( $F_{DMS}$ ) were derived by applying the COARE gas exchange coefficient for DMS to the DMS gradient at the ocean surface ( $\Delta DMS$ ):

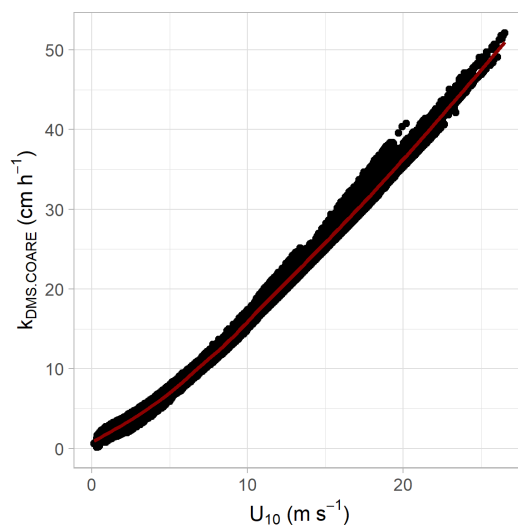
$$705 \quad F_{DMS} = k_{DMS,COARE} \times \Delta DMS \quad (1)$$

where  $k_{DMS,COARE}$  is the gas exchange coefficient for DMS. The sea–air DMS concentration difference  $\Delta DMS$  is equivalent to:

$$\Delta DMS = DMS_w - \frac{DMS_a}{H_{DMS}} \quad (2)$$

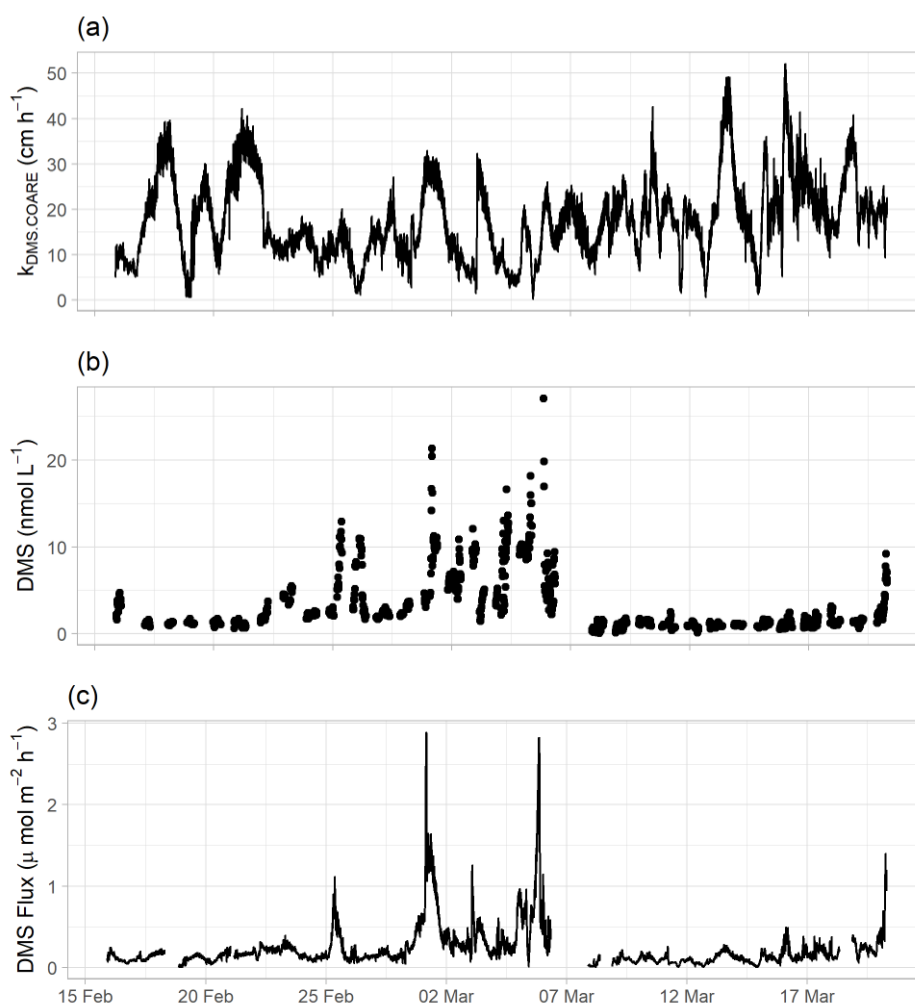
where  $H_{DMS}$  is the temperature dependent dimensionless Henry's law solubility coefficient for DMS (Dacey et al., 1984),  $DMS_w$  is the measured DMS concentration in seawater and  $DMS_a$  is the DMS concentrations in air. The transfer velocity  $k_{DMS,COARE}$  was calculated using the NOAA COAREG version 3.6 algorithm (Fairall et al., 2003, 2011; Blomquist et al., 2006) and parameterized in terms of local wind speed scaled to 10 m height as described in Bell et al. (2015). The transfer velocity  $k_{DMS,COARE}$  was then adapted for DMS using the Schmidt number for local seawater temperature and salinity at 6.0 m depth (Saltzman et al., 1993). For the flux calculations the  $DMS_a$  concentrations were set to zero as the atmospheric concentration is negligible compared to the concentrations in the ocean surface (ppt to nmol L<sup>-1</sup>).

As shown in Fig. 20 the transfer velocity is strongly dependent on wind speed. There is a positive correlation for the data set as a whole, with the transfer coefficient exhibiting the largest values at high wind speeds. As the sea–to–air DMS flux, shown in Fig. 21, depends on the DMS seawater concentrations, its distribution is very similar to that of dissolved DMS. The maximum DMS flux in the Southern Ocean is 69.4  $\mu\text{mol m}^{-2}\text{d}^{-1}$ , which corresponds to the maximum DMS concentrations measured in the Eastern Ross Sea. Yang et al. (2011) calculated an averaged DMS sea–to–air flux using the eddy covariance method of  $2.9 \pm 2.1 \mu\text{mol m}^{-2} \text{d}^{-1}$  derived from measurements made during the Southern Ocean Gas Exchange Experiment voyage, North of the Weddell Sea in March–April 2008. The median flux estimated here for the summertime Southern Ocean (south of 60° S) was of similar magnitude with  $3.57 \mu\text{mol m}^{-2}\text{d}^{-1}$ .



**Figure 20.** DMS gas transfer velocity  $k_{DMS.COARE}$  against the horizontal wind speed at 10 m. The red line represents a spline fit to the data.





**Figure 21.** Time series of (a) DMS transfer velocity, (b) dissolved DMS concentration and (c) estimated DMS flux to the atmosphere plotted against time in UTC.

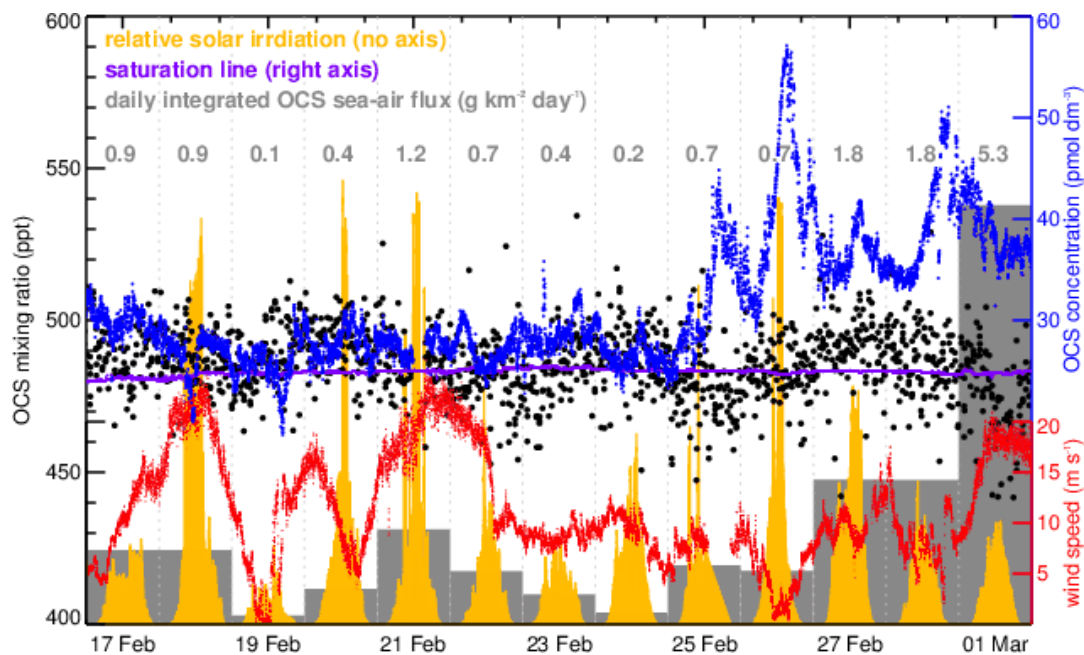


### 4.3.2 Surface seawater and atmospheric OCS

725 MICA operated from 9 February until 10 March 2018, when it was turned off after a cavity pressure drop caused by an internal blockage that could not be fixed at sea. Several measurement gaps between 9 February and 16 February were caused by power and seawater supply issues. Between 1 March and 8 March, salt jammed the 3-way switching valve in the air sampling position until the valve was cleaned with millipore water and ethanol. Quality assured dissolved OCS concentrations in surface seawater as measured during the TAN1802 voyage along the ship track are shown in Fig. 4(d).

730 MICA observations for the period 16 February to 1 March 2018, the time period without significant interruptions in either air or seawater sampling, are shown in Fig. 22. For OCS, atmospheric mixing ratios remain nearly constant around 500 ppt and dissolved concentrations vary between 20 and 60  $\text{pmol dm}^{-3}$ . OCS is nearly always supersaturated and follows a characteristic diel cycle of a photochemically produced gas. Within the region sampled between 16 February to 1 March, uncalibrated fluorescent dissolved organic matter (fDOM) data from an in-line sensor show diel variability but low spatial variability during  
735 this period (data not shown). fDOM refers to the fraction of CDOM (chromophoric dissolved organic matter) that fluoresces. As expected, Fig. 22 shows a relationship between OCS concentration and irradiance, as CDOM is the main precursor to OCS photoproduction (Ferek and Andreae, 1984). Besides photoproduction, wind speed (red line in Fig. 22) is a key driver to the observed variability of integrated daily fluxes (grey bars and numbers in Fig. 22). Daily fluxes are derived using the sea–air gas exchange parameterisation of Nightingale et al. (2000), and were integrated from 12:00 pm to 12:00 pm UTC. In the cold  
740 sub-Antarctic waters, the strongly temperature dependent OCS hydrolysis (Elliott et al., 1989) becomes slow with a lifetime of several days, and sea–air exchange becomes the dominant OCS removal process in the surface seawater. This explains the observed behaviour of dissolved OCS concentration with high supersaturation, only building up at low to moderate winds when photoproduction is greater than removal, and high OCS fluxes often coincide with lower seawater concentrations on windy days. Observations from the TAN1802 voyage will be used to assess whether the behaviour of OCS in the Southern  
745 Ocean is adequately represented by a state of the art photochemical model (Lennartz et al., 2017). A specific model setup forced with high resolution observations made during the cruise will help to improve and fine tune the model.

Besides OCS, MICA also measured CO and CO<sub>2</sub> with spikes related to contamination by the ship's exhaust are removed from the data set. Atmospheric CO mixing ratios are, on average, 27 ppb, which is 10–20 ppb lower than expected even for the pristine air in this region (e.g. Novelli et al., 1998). While we can not irrevocably rule out an artifact, we found no indication  
750 in the raw spectra or during calibrations for a measurement error beyond the 10 ppb accuracy. Dissolved CO concentrations in the nM range agree with earlier CO measurements in the Southern Ocean (Williams and Bainbridge, 1973; Swinnerton and Lamontagne, 1974; Bates et al., 1995; Wingenter et al., 2004). CO is also photochemically produced from CDOM (Wilson et al., 1970; Stubbins et al., 2006), but the low amplitude of the diel cycle and the sustained high supersaturation ratios of 10–80 even on days with high wind and moderate irradiation suggest significant production mechanisms in addition to photochemical  
755 production. Atmospheric CO<sub>2</sub> mixing ratios were close to 400 ppm throughout the cruise, which agrees with the Picarro measurements (Sect. 4.2.1) within uncertainties.



**Figure 22.** Time series of OCS atmospheric mixing ratios (black) and dissolved concentrations (blue) measured by MICA between 16 February and 1 March; data for other times are available but with significant interruptions (for more detail see text). Also shown are daily integrated sea-to-air OCS fluxes in  $\text{g km}^{-2} \text{day}^{-1}$  (grey bars and numbers), approximate saturation threshold (purple), wind speed (red) and irradiation (yellow, not scaled against an axis in terms of absolute numbers).

Two data files are provided for the MICA data: (i) atmospheric and dissolved OCS, CO and CO<sub>2</sub> concentrations at 2 minute temporal resolution and (ii) OCS sea-air flux at 1 hour temporal resolution (see Table A1). Note that OCS observations from TAN1802 have already been included in a long term global data set of ship based observations of atmospheric and dissolved  
760 OCS published by Lennartz et al. (2020).

## 5 Summary

Ground-based and ship-based measurements of cloud and aerosol properties over the remote Southern Ocean are sparse such that satellite-based measurements are the primary source of data in this region. However, satellite-based measurements are inherently limited in their utility in several ways, e.g., while CCN concentrations can be indirectly estimated, they can not be  
765 accurately determined from satellite-based measurements. As a result, many questions can only be addressed using in situ and remote sensing ground-based and/or ship-based measurements that observe the atmosphere from below. Incomplete understanding of aerosol-cloud interactions over the Southern Ocean leads to a misrepresentation of aerosol and clouds processes in climate models. Such misrepresentations are manifested as biases in the representation of precipitation and radiation by climate models over the Southern Ocean.



770 A comprehensive description of meteorological, aerosol, cloud and precipitation measurements, made using a suite of sen-  
sors on board the New Zealand research vessel Tangaora during a six-week voyage over the Southern Ocean during February  
and March 2018, has been presented above. These ship-borne measurements are an important supplement to satellite-based  
measurements as they provide data on low-level clouds and aerosol composition in the marine boundary layer that cannot  
be inferred from satellite-based measurements alone. As such, the ship-borne measurements can be used to investigate some  
775 of the processes that lead to biases in climate model representations of cloud–aerosol interactions that would otherwise not  
be amenable to diagnosis from satellite-based measurements alone. When both satellite- and surface-based measurements  
are used in conjunction with model studies, the synoptically varying vertical structure of Southern Ocean boundary layer and  
clouds, as well as variability of sources and sinks of CCN, aerosols, and the role of local biogenic sources can be investigated.

## 6 Code availability

780 The *mpl2nc* source code to convert raw MiniMPL data files to netCDF files is available at <https://github.com/peterkuma/mpl2nc>. The ALCF open source command line tool for processing of automatic lidar and ceilometer (ALC) data is available  
at <https://alcf-lidar.github.io/>. The tool to convert micro rain radar data into netCDF format is available from <https://github.com/peterkuma/mrr2c>. The COARE gas exchange algorithm to calculate the transfer velocity for sea-air flux estimates can be  
obtained from the NOAA ftp server ([ftp1.esrl.noaa.gov/BLO/Air-Sea/bulkalg/cor3\\_6](ftp1.esrl.noaa.gov/BLO/Air-Sea/bulkalg/cor3_6)). Open-source software to convert native  
785 radiosonde data into netCDF format is available at <https://github.com/peterkuma/rstool>.

## 7 Data availability

The TAN1802 voyage measurements described in this study are publicly available in netCDF format from Zenodo at <https://doi.org/10.5281/zenodo.4060237> (Kremser et al., 2020). These are packaged in a set of product ZIP archives by instrument  
and processing level (see also Table A1 for an overview on what is available). The AERONET Maritime Aerosol Network  
790 (MAN) hand-held sun photometer data are available directly from the MAN website for the TAN1802 voyage.

## Appendix A: Data products overview



**Table A1.** Overview of data products available from the Zenodo TAN1802 data archive for different processing levels, i.e. level 0: Raw (unformatted) data, level 1: Raw data formatted into netCDF format and quality controlled as described in the main text of the paper, and level 2: Derived parameters such as sea–air fluxes.

Name	Instrument	Processing level	Format
radiosondes	InterMet iMet-1-ABxn and Windsond Radiosonde	0 and 1	native/netCDF
picarro_crds	Picarro Cavity Ring-Down Spectrometer	1	netCDF
ceilometer	Lufft CHM 15k ceilometer	0	netCDF
ceilometer_alcf <sup>a</sup>	Lufft CHM 15k ceilometer	1	netCDF
mimimpl <sup>b</sup>	Sigma Space MiniMPL	0	binary
minimpl_alcf <sup>a</sup>	Sigma Space MiniMPL	1	netCDF
minimpl_mpl2nc <sup>c</sup>	Sigma Space MiniMPL	1	netCDF
mrr2	Metek Micro Rain Radar	0 and 1	text files/netCDF
allskypi	Raspberry Pi sky camera	1	JPEG/netCDF
bcc200	Brinno BCC200 sky camera	0	AVI
pcasp	Optical Particle Counter	1	netCDF
ccn100	Cloud Condensation Nuclei Counter	1	netCDF
cpc3010	Condensation Particle Counter	1	netCDF
smps3936	Scanning Mobility Particle Size Spectrometer	1	netCDF
nais	Neutral cluster and Air Ion Spectrometer	1	netCDF
alphasense_opc	UAV and helikite	1	CSV/netCDF
inp_filter_sampler	Filter Sampler for INPs	1	netCDF
gc_scd	Gas Chromatograph - Sulfur chemiluminescent detector	1 and 2	netCDF
mica	Mid-Infrared CAvity enhanced spectrometer	1	netCDF
ocs_flux	Mid-Infrared CAvity enhanced spectrometer	2	netCDF
das	Data Acquisition System	1	netCDF
weather_obs	Human observations	0	csv
trajectories <sup>d</sup>	Fraction of back trajectories spent over certain regions	2	netCDF

<sup>a</sup> Output obtained from ALCF tool, <sup>b</sup> contains calibration files (mimimpl\_calibration), <sup>c</sup> output from *mpl2nc* tool, and <sup>d</sup> more information in Hartery et al. (2020).

<https://doi.org/10.5194/essd-2020-321>  
Preprint. Discussion started: 9 November 2020  
© Author(s) 2020. CC BY 4.0 License.



## **Appendix B: Radiosonde releases, helikite and UAV flights**



**Table B1.** Release date, time and location of all radiosondes releases as well as helikite and UAV flights.

Instrument	Time (ISO 8601 UTC)	Latitude	Longitude	Station number	Launch number
iMet	2018-02-13 01:46	58°02.02'S	174°13.10'E	009	#1
iMet	2018-02-14 00:47	61°00.95'S	173°29.44'E	021	#2
iMet	2018-02-15 00:20	64°40.58'S	170°57.39'E	030	#3
iMet	2018-02-15 07:33	65°29.39'S	171°47.62'E	036	#4
iMet	2018-02-16 00:10	67°50.61'S	172°50.92'E	041	#5
iMet	2018-02-16 07:40	68°38.97'S	172°47.87'E	044	#6
Windsond	2018-02-16 18:47	70°24.06'S	172°35.52'E	046	N/A
Windsond	2018-02-16 21:16	70°46.86'S	172°33.24'E	047	N/A
iMet	2018-02-17 00:11	70°58.15'S	172°32.02'E	048	#7
Windsond	2018-02-17 00:52	71°13.38'S	172°30.36'E	049	N/A
Windsond	2018-02-17 04:38	71°25.86'S	172°32.52'E	051	N/A
Windsond	2018-02-18 06:00	71°26.82'S	171°59.22'E	056	N/A
Windsond	2018-02-18 21:27	71°30.60'S	171°45.18'E	063	N/A
iMet	2018-02-19 00:31	71°30.87'S	171°40.37'E	066	#8
Windsond	2018-02-19 03:04	71°38.64'S	171°42.66'E	068	N/A
iMet	2018-02-20 07:31	71°56.21'S	171°55.89'E	078	#10
Windsond	2018-02-21 00:00	71°50.34'S	174°23.04'E	085	N/A
iMet	2018-02-22 03:39	72°41.05'S	178°12.36'W	086	#11
iMet	2018-02-22 07:50	72°59.14'S	177°15.18'W	088	#12
iMet	2018-02-23 02:18	73°00.47'S	177°07.17'W	093	#13
iMet	2018-02-23 07:31	72°50.67'S	176°43.39'W	095	#14
iMet	2018-02-24 00:01	72°19.68'S	178°52.17'W	100	#15
iMet	2018-02-24 07:26	72°26.35'S	179°09.89'W	103	#16
iMet	2018-02-25 00:02	72°11.56'S	178°29.18'W	111	#17
iMet	2018-02-25 06:17	72°05.03'S	178°03.53'W	112	#18
Windsond	2018-02-25 22:02	71°16.32'S	177°59.52'W	115	N/A
Helikite	2018-02-26 02:34	71°13.81'S	178°03.58'W	117	N/A
iMet	2018-02-27 00:02	71°00.34'S	179°37.80'E	120	#19
iMet	2018-02-28 00:10	70°56.05'S	179°57.72'E	131	#21
iMet	2018-02-28 07:53	70°53.14'S	178°59.57'W	135	#22
iMet	2018-03-01 19:34	69°31.04'S	178°17.11'W	140	#24
iMet	2018-03-02 00:01	69°29.84'S	177°56.63'W	143	#25
iMet	2018-03-02 07:59	69°29.14'S	179°33.22'W	145	#26

Legend: Not available (N/A), iMet-1-ABxn radiosonde (**iMet**), Windsond radiosonde (**Windsond**).



**Table B2.** Release date, time and location of all radiosondes releases as well as helikite and UAV flights. (cont.).

Instrument	Time (ISO 8601 UTC)	Latitude	Longitude	Station number	Launch number
iMet	2018-03-02 19:35	69°08.76'S	177°48.10'W	146	#27
iMet	2018-03-03 00:09	69°04.66'S	178°06.52'W	150	#28
UAV	2018-03-03 00:34	69°02.11'S	178°01.92'W	151	N/A
iMet	2018-03-03 07:32	69°01.09'S	178°58.81'W	153	#29
iMet	2018-03-03 19:48	68°56.47'S	178°56.01'W	154	#30
iMet	2018-03-04 00:34	68°51.46'S	178°44.80'W	158	#31
iMet	2018-03-04 19:47	68°20.03'S	179°58.32'W	163	#32
Windsond	2018-03-05 07:31	68°10.74'S	179°58.08'W	171	N/A
iMet	2018-03-06 20:08	66°44.56'S	177°09.52'W	173	#34
Windsond	2018-03-06 22:21	66°36.78'S	177°27.30'W	176	N/A
iMet	2018-03-07 00:04	66°38.73'S	177°22.30'W	178	#35
Windsond	2018-03-07 04:44	66°43.56'S	177°10.44'W	181	N/A
iMet	2018-03-07 07:40	66°44.51'S	177°04.00'W	183	#36
iMet	2018-03-07 19:49	66°45.39'S	177°01.48'W	187	#37
iMet	2018-03-08 00:09	66°57.30'S	176°13.38'W	190	#38
iMet	2018-03-08 07:37	66°55.15'S	176°16.24'W	194	#39
iMet	2018-03-09 00:13	67°07.69'S	175°40.01'W	205	#40
iMet	2018-03-09 07:36	67°02.58'S	175°36.87'W	206	#41
iMet	2018-03-09 19:50	67°10.77'S	175°25.57'W	210	#42
iMet	2018-03-10 00:18	67°08.99'S	175°30.05'W	214	#43
iMet	2018-03-10 07:33	66°52.08'S	176°28.49'W	215	#44
iMet	2018-03-10 19:44	66°22.13'S	177°45.99'W	217	#45
iMet	2018-03-11 00:41	66°17.64'S	178°31.03'W	221	#46
iMet	2018-03-11 07:32	66°16.37'S	179°21.91'W	223	#47
iMet	2018-03-11 19:45	65°27.60'S	179°25.27'E	227	#48
iMet	2018-03-12 00:12	65°11.40'S	179°06.63'E	231	#49
iMet	2018-03-12 07:38	64°36.50'S	178°13.59'E	234	#50
iMet	2018-03-12 20:11	63°40.00'S	176°06.68'E	236	#51
iMet	2018-03-13 00:35	63°31.75'S	176°05.52'E	240	#52
iMet	2018-03-13 07:50	62°59.00'S	176°07.15'E	242	#54
iMet	2018-03-14 00:12	62°03.87'S	174°58.88'E	243	#55
iMet	2018-03-14 07:47	62°17.83'S	175°08.36'E	244	#56
iMet	2018-03-14 20:02	63°10.46'S	174°27.50'E	246	#57
iMet	2018-03-15 00:23	62°56.37'S	174°18.31'E	251	#58
iMet	2018-03-15 07:42	61°50.72'S	173°46.18'E	252	#59

Legend: Not available (N/A), iMet-1-ABxn radiosonde (iMet), Windsond radiosonde (Windsond).





*Author contributions.* All co-authors contributed data from one or more instruments and provided relevant figures and material for the manuscript. PK participated in the organisation of the voyage and deployment of instruments, performed observations during the voyage, 795 post-processed a part of the data set, and developed the mpl2nc, mrr2c, rstool and ALCF software packages. SH maintained and ran the aerosol instruments during the voyage and prepared all aerosol data sets (except from the NAIS instrument). MP prepared the NAIS data, and together with KS prepared the required material for the manuscript. KS shipped the NAIS from France and installed the NAIS on the Tangaroa prior to the voyage and performed remote quality checks of the data during voyage. JM participated in the voyage, and prepared and quality controlled the CO<sub>2</sub> measurements. AM was responsible for collecting DMS and OCS measurements during the voyage. AS-M 800 was in charge of the QA/QC of the dissolved DMS measurements, and together with MH and CSL provided the figures and material for the paper. MH led the collaborative proposal for the aerosol–cloud component of the voyage and calculated the DMS fluxes. RQ provided the MiniMPL instrument for the voyage and processed the data, AG developed the allskypi system and software and prepared the allskypi data. STL and MvH provided, prepared and quality checked the MICA instrument assembly and prepared MICA related data. AMcD prepared the rain radar data. IS and CF took part in the processing and calibration of the MiniMPL data. TH, PDeM, and CH analysed and provided the 805 INP data. GG designed and build the particle sensing AlphaSense radiosonde equipment used for measurements with the UAV. SP prepared and installed the meteorological equipment, such as ceilometer, micro rain radar, Brinno sky cameras and provided logistical support. SK wrote the manuscript with contributions from all co-authors.

*Competing interests.* The authors declare that they have no conflict of interest.

*Acknowledgements.* We thank the vessel master Evan Solly, all officers, crew and the voyage leader Dr David Bowden of the TAN1802 810 voyage. We would also like to thank Gordon Brailsford for providing the Picarro instrument and Josh McCulloch for designing the Alphasense OPC unit with an RTC clock for the use with the UAV. We thank Tony Bromley from NIWA for supplying and preparing the helikite and Windsond systems used during the voyage and International Met Systems (InterMet) for providing the radiosonde base station iMet-3050A. We acknowledge the financial support provided by the Deep South National Science Challenge via the Clouds and Aerosols project. The voyage was supported through a New Zealand Crown Funding Agreement and associated voyage science was funded through the NIWA 815 Research Programme in Ocean-Climate Interactions (2017/19 SCI). PK and SH both acknowledge independently awarded scholarships provided by the University of Canterbury and the Deep South National Science Challenge. PK's contribution was partially self-funded (Peter Kuma Software & Science, peterkuma.net). This project has also received support from ANR T-ERC Sea2Cloud and from the European Research Council (ERC) under the European Union's Horizon 2020 research and innovation programme (grant agreement No 771369). TH, PDeM and CH acknowledge partial support from U.S. National Science Foundation Award 1660486.



## 820 References

- Agresti, A. and Coull, B. A.: Approximate Is Better than "Exact" for Interval Estimation of Binomial Proportions, *The American Statistician*, 52, 119–126, 1998.
- Alroe, J., Cravigan, L. T., Miljevic, B., Johnson, G. R., Selleck, P., Humphries, R. S., Keywood, M. D., Chambers, S. D., Williams, A. G., and Ristovski, Z. D.: Marine productivity and synoptic meteorology drive summer-time variability in Southern Ocean aerosols, *Atmospheric Chemistry and Physics*, 20, 8047–8062, <https://doi.org/10.5194/acp-20-8047-2020>, 2020.
- 825 Baer, D. S., B., P. J., Gupta, M., and A., O.: Sensitive absorption measurements in the near-infrared region using off-axis integrated cavity output spectroscopy, *Applied Physics B*, 75, 261–265, <https://doi.org/10.1007/s00340-002-0971-z>, 2002.
- Bates, T. S., Kelly, K. C., Johnson, J. E., and Gammon, R. H.: Regional and seasonal variations in the flux of oceanic carbon monoxide to the atmosphere, *Journal of Geophysical Research: Atmospheres*, 100, 23 093–23 101, <https://doi.org/10.1029/95JD02737>, 1995.
- 830 Bates, T. S., Huebert, B. J., Gras, J. L., Griffiths, F. B., and Durkee, P. A.: International Global Atmospheric Chemistry (IGAC) Project's First Aerosol Characterization Experiment (ACE 1): Overview, *Journal of Geophysical Research: Atmospheres*, 103, 16 297–16 318, <https://doi.org/10.1029/97JD03741>, 1998.
- Bell, T. G., De Bruyn, W., Marandino, C. A., Miller, S. D., Law, C. S., Smith, M. J., and Saltzman, E. S.: Dimethylsulfide gas transfer coefficients from algal blooms in the Southern Ocean, *Atmospheric Chemistry and Physics*, 15, 1783–1794, [https://doi.org/10.5194/acp-](https://doi.org/10.5194/acp-15-1783-2015)
- 835 15-1783-2015, 2015.
- Bigg, E. K.: Ice Nucleus Concentrations in Remote Areas, *Journal of the Atmospheric Sciences*, 30, 1153–1157, [https://doi.org/10.1175/1520-0469\(1973\)030<1153:INCIRA>2.0.CO;2](https://doi.org/10.1175/1520-0469(1973)030<1153:INCIRA>2.0.CO;2), 1973.
- Blomquist, B. W., Fairall, C. W., Huebert, B. J., Kieber, D. J., and Westby, G. R.: DMS sea-air transfer velocity: Direct measurements by eddy covariance and parameterization based on the NOAA/COARE gas transfer model, *Geophysical Research Letters*, 33, <https://doi.org/10.1029/2006GL025735>, 2006.
- 840 Bodas-Salcedo, A., Williams, K. D., Field, P. R., and Lock, A. P.: The Surface Downwelling Solar Radiation Surplus over the Southern Ocean in the Met Office Model: The Role of Midlatitude Cyclone Clouds, *Journal of Climate*, 25, 7467–7486, <https://doi.org/10.1175/JCLI-D-11-00702.1>, 2012.
- Bodas-Salcedo, A., Mulcahy, J. P., Andrews, T., Williams, K. D., Ringer, M. A., Field, P. R., and Elsaesser, G. S.: Strong Dependence of Atmospheric Feedbacks on Mixed-Phase Microphysics and Aerosol-Cloud Interactions in HadGEM3, *Journal of Advances in Modeling Earth Systems*, 11, 1735–1758, <https://doi.org/10.1029/2019MS001688>, 2019.
- 845 Brailsford, G. W., Stephens, B. B., Gomez, A. J., Riedel, K., Mikaloff Fletcher, S. E., Nichol, S. E., and Manning, M. R.: Long-term continuous atmospheric CO<sub>2</sub> measurements at Baring Head, New Zealand, *Atmospheric Measurement Techniques*, 5, 3109–3117, <https://doi.org/10.5194/amt-5-3109-2012>, 2012.
- 850 Brühl, C., Lelieveld, J., Crutzen, P., and Tost, H.: The role of carbonyl sulphide as a source of stratospheric sulphate aerosol and its impact on climate, *Atmospheric Chemistry and Physics*, 12, 1239–1253, 2012.
- Campbell, J. R., Hlavka, D. L., Welton, E. J., Flynn, C. J., Turner, D. D., Spinhirne, J. D., Scott III, V. S., and Hwang, I.: Full-time, eye-safe cloud and aerosol lidar observation at atmospheric radiation measurement program sites: Instruments and data processing, *Journal of Atmospheric and Oceanic Technology*, 19, 431–442, [https://doi.org/10.1175/1520-0426\(2002\)019<0431:FTESCA>2.0.CO;2](https://doi.org/10.1175/1520-0426(2002)019<0431:FTESCA>2.0.CO;2), 2002.



- 855 Chen, Q., Sherwen, T., Evans, M., and Alexander, B.: DMS oxidation and sulfur aerosol formation in the marine troposphere: a focus on reactive halogen and multiphase chemistry, *Atmospheric Chemistry and Physics*, 18, 13 617–13 637, <https://doi.org/10.5194/acp-18-13617-2018>, 2018.
- Crutzen, P.: The possible importance of CSO for the sulfate layer of the stratosphere, *Geophysical Research Letters*, 3, 73–76, 1976.
- Dacey, J. W. H., Wakeham, S. G., and Howes, B. L.: Henry’s law constants for dimethylsulfide in freshwater and seawater, *Geophysical*  
860 *Research Letters*, 11, 991–994, <https://doi.org/10.1029/GL011i010p00991>, 1984.
- DeMott, P., Hill, T., and McFarquhar, G.: Measurements of Aerosols, Radiation, and Clouds over the Southern Ocean (MARCUS) Ice Nucleating Particle Measurements Field Campaign Report Field Campaign Report, DOE/SC-ARM-18-031, report available from <https://www.arm.gov/publications/programdocs/doe-sc-arm-18-031.pdf>, last accessed 22 Oct 2020, 2018.
- Elliott, S., Lu, E., and Rowland, F. S.: Rates and mechanisms for the hydrolysis of carbonyl sulfide in natural waters, *Environmental Science*  
865 *& Technology*, 23, 458–461, <https://doi.org/10.1021/es00181a011>, 1989.
- Fairall, C. W., Bradley, E. F., Hare, J. E., Grachev, A. A., and Edson, J. B.: Bulk Parameterization of Air–Sea Fluxes: Updates and Verification for the COARE Algorithm, *Journal of Climate*, 16, 571–591, [https://doi.org/10.1175/1520-0442\(2003\)016<0571:BPOASF>2.0.CO;2](https://doi.org/10.1175/1520-0442(2003)016<0571:BPOASF>2.0.CO;2), 2003.
- Fairall, C. W., Yang, M., Bariteau, L., Edson, J. B., Helmig, D., McGillis, W., Pezoa, S., Hare, J. E., Huebert, B., and Blomquist, B.:  
870 Implementation of the Coupled Ocean–Atmosphere Response Experiment flux algorithm with CO<sub>2</sub>, dimethyl sulfide, and O<sub>3</sub>, *Journal of Geophysical Research*, 116, <https://doi.org/10.1029/2010JC006884>, 2011.
- Ferek, R. and Andreae, M.: Photochemical production of carbonyl sulphide in marine surface waters, *Nature*, 307, 148–150, <https://doi.org/10.1038/307148a0>, 1984.
- Flynn, C. J., Mendozaa, A., Zhengb, Y., and Mathurb, S.: Novel polarization-sensitive micropulse lidar measurement technique, *Optics*  
875 *express*, 15, 2785–2790, <https://doi.org/10.1364/OE.15.002785>, 2007.
- Fossum, K. N., Ovadnevaite, J., Ceburnis, D., Dall’Osto, M., Marullo, S., Bellacicco, M., Simo, R., Liu, D., Flynn, M., Zuend, A., and O’Dowd, C.: Summertime Primary and Secondary Contributions to Southern Ocean Cloud Condensation Nuclei, *Scientific Reports*, 8, <https://doi.org/10.1038/s41598-018-32047-4>, 2018.
- Hamilton, D. S., Lee, L. A., Pringle, K. J., Reddington, C. L., Spracklen, D. V., and Carslaw, K. S.: Occurrence of pristine aerosol environments on a polluted planet, *Proceedings of the National Academy of Sciences*, 111, 18 466–18 471, <https://doi.org/10.1073/pnas.1415440111>, 2014.
- Hartery, S., Toohey, D., Revell, L., Sellegrì, K., Kuma, P., Harvey, M., and McDonald, A. J.: Constraining the surface flux of sea spray particles from the Southern Ocean, *Journal of Geophysical Research*, 125, e2019JD032 026, <https://doi.org/10.1029/2019JD032026>, 2020.
- Haynes, J., Jakob, C., Rossow, W., Tselioudis, G., and Brown, J.: Major Characteristics of Southern Ocean Cloud Regimes and Their Effects  
885 on the Energy Budget, *Journal of Climate*, 24, 5061–5080, <https://doi.org/10.1175/2011JCLI4052.1>, 2011.
- Hiranuma, N., Augustin-Bauditz, S., Bingemer, H., Budke, C., Curtius, J., Danielczok, A., Diehl, K., Dreischmeier, K., Ebert, M., Frank, F., Hoffmann, N., Kandler, K., Kiselev, A., Koop, T., Leisner, T., Möhler, O., Nillius, B., Peckhaus, A., Rose, D., Weinbruch, S., Wex, H., Boose, Y., DeMott, P. J., Hader, J. D., Hill, T. C. J., Kanji, Z. A., Kulkarni, G., Levin, E. J. T., McCluskey, C. S., Murakami, M., Murray, B. J., Niedermeier, D., Petters, M. D., O’Sullivan, D., Saito, A., Schill, G. P., Tajiri, T., Tolbert, M. A., Welti, A., Whale, T. F., Wright, T. P., and Yamashita, K.: A comprehensive laboratory study on the immersion freezing behavior of illite NX particles: a comparison of 17  
890 ice nucleation measurement techniques, *Atmospheric Chemistry and Physics*, 15, 2489–2518, <https://doi.org/10.5194/acp-15-2489-2015>, 2015.



- Hoffmann, E., Tilgner, A., Schrödner, R., Bräuer, P., Wolke, R., and Herrmann, H.: An advanced modeling study on the impacts and atmospheric implications of multiphase dimethyl sulfide chemistry, *Proceedings of the National Academy of Sciences*, 113, 11 776–11 781, 895 <https://doi.org/10.1073/pnas.1606320113>, 2016.
- Huertas-Tato, J., Rodríguez-Benítez, F. J., Arbizu-Barrena, C., Aler-Mur, R., Galvan-Leon, I., and Pozo-Vázquez, D.: Automatic Cloud-Type Classification Based On the Combined Use of a Sky Camera and a Ceilometer, *Journal of Geophysical Research*, 122, 11,045–11,061, <https://doi.org/10.1002/2017JD027131>, 2017.
- Hultin, K. A. H., Nilsson, E. D., Krejci, R., Mårtensson, E. M., Ehn, M., Hagström, , and de Leeuw, G.: In situ laboratory sea spray 900 production during the Marine Aerosol Production 2006 cruise on the northeastern Atlantic Ocean, *Journal of Geophysical Research*, 115, <https://doi.org/10.1029/2009JD012522>, 2010.
- Humphries, R. S., Klekociuk, A. R., Schofield, R., Keywood, M., Ward, J., and Wilson, S. R.: Unexpectedly high ultrafine aerosol concentrations above East Antarctic sea ice, *Atmospheric Chemistry and Physics*, 16, 2185–2206, <https://doi.org/10.5194/acp-16-2185-2016>, 2016.
- 905 Hyder, P., Edwards, J., Allan, R., Hewitt, H., Bracegirdle, T., Gregory, J., Wood, R., Meijers, A., Mulcahy, J., Field, P., Furtado, K., Bodas-Salcedo, A., Williams, K., Copsey, D., Josey, S., Liu, C., Roberts, C., Sanchez, C., Ridley, J., Thorpe, L., Hardiman, S., Mayer, M., Berry, D., and Belcher, S.: Critical Southern Ocean climate model biases traced to atmospheric model cloud errors, *Nature Communications*, 9, <https://doi.org/10.1038/s41467-018-05634-2>, 2018.
- Kay, J., Wall, C., Yettella, V., Medeiros, B., Hannay, C., Caldwell, P., and Bitz, C. M.: Global Climate Impacts of Fixing the 910 Southern Ocean Shortwave Radiation Bias in the Community Earth System Model (CESM), *Journal of Climate*, 29, 4617–4636, <https://doi.org/10.1175/JCLI-D-15-0358.1>, 2016.
- Kettle, A., Kuhn, U., von Hobe, M., Kesselmeier, J., and Andreae, M.: Global Budget of atmospheric carbonyl sulfide: Temporal and spatial variations of the dominant sources and sinks, *Journal of Geophysical Research*, 107, <https://doi.org/10.1029/2002JD002187>, 2002.
- Klekociuk, A. R., French, W. J. R., Alexander, S. P., Kuma, P., and McDonald, A. J.: The state of the atmosphere in 915 the 2016 southern Kerguelen Axis campaign region, *Deep Sea Research Part II: Topical Studies in Oceanography*, 174, <https://doi.org/https://doi.org/10.1016/j.dsr2.2019.02.001>, 2020.
- Kremser, S., Thomason, L., von Hobe, M., Hermann, M., Deshler, T., Timmreck, C., Toohey, M., Stenke, A., Schwarz, J., Weigel, R., Fueglistaler, S., Prata, F., Vernier, J., Schlager, H., Barnes, J., Antuña-Marrero, J.-C., Fairlie, D., Palm, M., Mahieu, E., Notholt, J., Rex, M., Bingen, C., Vanhellefont, F., Bourassa, A., Plane, J., Klocke, D., Carn, S., Clarisse, L., Trickl, T., Neely, R., James, A., Rieger, 920 L., Wilson, J., and Meland, B.: Stratospheric aerosol - Observations, processes, and impact on climate, *Reviews of Geophysics*, 54, <https://doi.org/10.1002/2015RG000511>, 2016.
- Kremser, S., Harvey, M., Kuma, P., Hartery, S., Saint-Macary, A., McGregor, J., Schuddeboom, A., von Hobe, M., Lennartz, S. T., Geddes, A., Querel, R., McDonald, A., Peltola, M., Sellegri, K., Silber, I., Law, C., Flynn, C. J., Marriner, A., Hill, T. C., DeMott, P., Hume, C. C., Plank, G., Graham, G., and Parsons, S.: Southern Ocean Cloud and Aerosol data set: a compilation of measurements from the 2018 925 Southern Ocean Ross Sea Marine Ecosystems and Environment voyage [Data set]., Zenodo, <https://doi.org/10.5281/zenodo.4060237>, 2020.
- Krüger, O. and Graßl, H.: Southern Ocean phytoplankton increases cloud albedo and reduces precipitation, *Geophysical Research Letters*, 38, <https://doi.org/10.1029/2011gl047116>, 2011.



- 930 Kuma, P., McDonald, A. J., Morgenstern, O., Querel, R., Silber, I., and Flynn, C. J.: Ground-based lidar processing and simulator framework for comparing models and observations (ALCF 1.0), *Geoscientific Model Development Discussions*, 2020, 1–45, <https://doi.org/10.5194/gmd-2020-25>, 2020.
- Lana, A., Bell, T. G., Simó, R., Vallina, S. M., Ballabrera-Poy, J., Kettle, A. J., Dachs, J., Bopp, L., Saltzman, E. S., Stefels, J., Johnson, J. E., and Liss, P. S.: An updated climatology of surface dimethylsulfide concentrations and emission fluxes in the global ocean, *Global Biogeochemical Cycles*, 25, <https://doi.org/10.1029/2010GB003850>, 2011.
- 935 Law, C. S., Smith, M. J., Harvey, M. J., Bell, T. G., Cravigan, L. T., Elliott, F. C., Lawson, S. J., Lizotte, M., Marriner, A., McGregor, J., Ristovski, Z., Safi, K. A., Saltzman, E. S., Vaattovaara, P., and Walker, C. F.: Overview and preliminary results of the Surface Ocean Aerosol Production (SOAP) campaign, *Atmospheric Chemistry and Physics*, 17, 13 645–13 667, <https://doi.org/10.5194/acp-17-13645-2017>, 2017.
- Lawson, P. and Gettelman, A.: Impact of Antarctic mixed-phase clouds on climate, *Proceedings of the National Academy of Sciences of the United States of America*, 111, <https://doi.org/10.1073/pnas.1418197111>, 2014.
- 940 Lennartz, S. T., Marandino, C. A., von Hobe, M., Cortes, P., Quack, B., Simo, R., Booge, D., Pozzer, A., Steinhoff, T., Arevalo-Martinez, D. L., Kloss, C., Bracher, A., Röttgers, R., Atlas, E., and Krüger, K.: Direct oceanic emissions unlikely to account for the missing source of atmospheric carbonyl sulfide, *Atmospheric Chemistry and Physics*, 17, 385–402, <https://doi.org/10.5194/acp-17-385-2017>, 2017.
- Lennartz, S. T., Marandino, C. A., von Hobe, M., Andreae, M. O., Aranami, K., Atlas, E., Berkelhammer, M., Bingemer, H., Booge, D., 945 Cutter, G., Cortes, P., Kremser, S., Law, C. S., Marriner, A., Simó, R., Quack, B., Uher, G., Xie, H., and Xu, X.: Marine carbonyl sulfide (OCS) and carbon disulfide (CS<sub>2</sub>): a compilation of measurements in seawater and the marine boundary layer, *Earth System Science Data*, 12, 591–609, <https://doi.org/10.5194/essd-12-591-2020>, 2020.
- Lothon, M., Barnéoud, P., Gabella, O., Lohou, F., Derrien, S., Rondi, S., Chiriaco, M., Bastin, S., Dupont, J.-C., Haffelin, M., Badosa, J., Pascal, N., and Montoux, N.: ELIFAN, an algorithm for the estimation of cloud cover 950 from sky imagers, *Atmospheric Measurement Techniques*, 12, 5519–5534, <https://doi.org/10.5194/amt-12-5519-2019>, 2019.
- Maahn, M. and Kollias, P.: Improved Micro Rain Radar snow measurements using Doppler spectra post-processing, *Atmospheric Measurement Techniques*, 5, 2661–2673, <https://doi.org/10.5194/amt-5-2661-2012>, 2012.
- Mace, G. G. and Protat, A.: Clouds over the Southern Ocean as Observed from the R/V Investigator during CAPRICORN. Part I: Cloud Occurrence and Phase Partitioning, *Journal of Applied Meteorology and Climatology*, 57, 1783–1803, <https://doi.org/10.1175/JAMC-D-17-0194.1>, 2018.
- 955 MAN website for the TAN1802 voyage: 2018 RV Tangaroa Cruise:, [https://aeronet.gsfc.nasa.gov/new\\_web/cruises\\_new/Tangaroa\\_18\\_0.html](https://aeronet.gsfc.nasa.gov/new_web/cruises_new/Tangaroa_18_0.html), last access: 30 September 2020.
- Manninen, H. E., Mirme, S., Mirme, A., Petäjä, T., and Kulmala, M.: How to reliably detect molecular clusters and nucleation mode particles with Neutral cluster and Air Ion Spectrometer (NAIS), *Atmospheric Measurement Techniques*, 9, 3577–3605, <https://doi.org/10.5194/amt-9-3577-2016>, 2016.
- 960 Marchand, R.: Macquarie Island Cloud and Radiation Experiment (MICRE) Field Campaign Report, DOE/SC-ARM-20-005, report available from <https://www.arm.gov/publications/programdocs/doe-sc-arm-20-005.pdf>, last accessed 22 Sept 2020., 2020.
- McCluskey, C. S., Hill, T. C. J., Humphries, R. S., Rauker, A. M., Moreau, S., Stratton, P. G., Chambers, S. D., Williams, A. G., McRobert, I., Ward, J., Keywood, M. D., Harnwell, J., Ponsonby, W., Loh, Z. M., Krummel, P. B., Protat, A., Kreidenweis, S. M., and De- 965 Mott, P. J.: Observations of Ice Nucleating Particles Over Southern Ocean Waters, *Geophysical Research Letters*, 45, 11,989–11,997, <https://doi.org/10.1029/2018GL079981>, 2018.



- McCoy, D., Burrows, S., Wood, R., Grosvenor, D., Elliott, S., Ma, P., Rasch, P., and Hartmann, D.: Natural aerosols explain seasonal and spatial patterns of Southern Ocean cloud albedo, *Science Advances*, 1, <https://doi.org/10.1126/sciadv.1500157>, 2015.
- McErlich, C., McDonald, A. J., Schuddeboom, A. J., and Silber, I.: Comparing satellite and ground-based observations of cloud occurrence  
970 over high southern latitudes, *Earth and Space Science Open Archive*, p. 39, <https://doi.org/10.1002/essoar.10503821.1>, 2020.
- McFarquhar, G., Marchand, R., Bretherton, C., Alexander, S., Protat, A., Siems, S., Wood, R., and DeMott, P.: Measurements of Aerosols, Radiation, and Clouds over the Southern Ocean (MARCUS) Field Campaign Report, DOE/SC-ARM-19-008, report available from <https://www.arm.gov/publications/programdocs/doi-sc-arm-19-008.pdf>, last accessed 22 Sept 2020, 2019.
- Mechoso, C. R., Losada, T., Koseki, S., Mohino-Harris, E., Keenlyside, N., Castaño-Tierno, A., Myers, T. A., Rodriguez-Fonseca, B., and  
975 Toniazzo, T.: Can reducing the incoming energy flux over the Southern Ocean in a CGCM improve its simulation of tropical climate?, *Geophysical Research Letters*, 43, 11,057–11,063, <https://doi.org/10.1002/2016GL071150>, 2016.
- Mertens, T., Kautz, J., and Van Reeth, F.: Exposure Fusion: A Simple and Practical Alternative to High Dynamic Range Photography, *Computer Graphics Forum*, 28, 161–171, <https://doi.org/10.1111/j.1467-8659.2008.01171.x>, 2009.
- Mirme, S. and Mirme, A.: The mathematical principles and design of the NAIS – a spectrometer for the measurement of cluster ion and  
980 nanometer aerosol size distributions, *Atmospheric Measurement Techniques*, 6, 1061–1071, <https://doi.org/10.5194/amt-6-1061-2013>, 2013.
- Mulcahy, J. P., O’Dowd, C. D., Jennings, S. G., and Ceburnis, D.: Significant enhancement of aerosol optical depth in marine air under high wind conditions, *Geophysical Research Letters*, 35, <https://doi.org/10.1029/2008GL034303>, 2008.
- Murphy, D. M., Anderson, J., Quinn, P., McInnes, L., Brechtel, F., Kreidenweis, S., Middlebrook, A., Posfai, M., Thomson, D., and Buseck,  
985 P.: Influence of sea-salt on aerosol radiative properties in the Southern Ocean marine boundary layer, *Letters to Nature*, 392, 1998.
- Myhre, G., Shindell, D., Bréon, F.-M., Collins, W., Fuglestedt, J., Huang, J., Koch, D., Lamarque, J.-F., Lee, D., Mendoza, B., Nakajima, T., Robock, A., Stephens, G., Takemura, T., and Zhang, H.: Anthropogenic and Natural Radiative Forcing. In: *Climate Change 2013: The Physical Science Basis, Contribution of Working Group I to the Fifth Assessment Report of the Intergovernmental Panel on Climate Change*, Cambridge University Press, Cambridge, United Kingdom and New York, NY, USA., 2013.
- 990 Nightingale, P. D., Malin, G., Law, C. S., Watson, A. J., Liss, P. S., Liddicoat, M. I., Boutin, J., and Upstill-Goddard, R. C.: In situ evaluation of air-sea gas exchange parameterizations using novel conservative and volatile tracers, *Global Biogeochemical Cycles*, 14, 373–387, <https://doi.org/10.1029/1999GB900091>, 2000.
- NIWA website: Specifications and principal features:, <https://niwa.co.nz/vessels/rv-tangaroa/specifications-and-principal-features>, last access: 30 September 2020.
- 995 Noh, Y.-J., Miller, S. D., Heidinger, A. K., Mace, G. G., Protat, A., and Alexander, S. P.: Satellite-Based Detection of Daytime Supercooled Liquid-Topped Mixed-Phase Clouds Over the Southern Ocean Using the Advanced Himawari Imager, *Journal of Geophysical Research: Atmospheres*, 124, 2677–2701, <https://doi.org/10.1029/2018JD029524>, 2019.
- Novelli, P. C., Masarie, K. A., and Lang, P. M.: Distributions and recent changes of carbon monoxide in the lower troposphere, *Journal of Geophysical Research*, 103, 19 015–19 033, <https://doi.org/10.1029/98JD01366>, 1998.
- 1000 O’Dowd, C. D., Smith, M. H., Consterdine, I. E., and Lowe, J. A.: Marine aerosol, sea-salt, and the marine sulphur cycle: a short review, *Atmospheric Environment*, 31, 73 – 80, [https://doi.org/https://doi.org/10.1016/S1352-2310\(96\)00106-9](https://doi.org/https://doi.org/10.1016/S1352-2310(96)00106-9), 1997.
- O’Keefe, A., Scherer, J. J., and Paul, J. B.: cw Integrated cavity output spectroscopy, *Chemical Physics Letters*, 307, 343–349, [https://doi.org/https://doi.org/10.1016/S0009-2614\(99\)00547-3](https://doi.org/https://doi.org/10.1016/S0009-2614(99)00547-3), 1999.



- O'Neill, N., Eck, T., Smirnov, A., Holben, B., and Thulasiraman, S.: Spectral discrimination of coarse and fine mode optical depth, *Journal of Geophysical Research*, 108, 4559, <https://doi.org/10.1029/2002JD002975>, 2003.
- Paul, J. B., Lapson, L., and Anderson, J.: Ultrasensitive Absorption Spectroscopy with a High-Finesse Optical Cavity and Off-Axis Alignment, *Applied Optics*, 40, 4904–10, <https://doi.org/10.1364/AO.40.004904>, 2001.
- Popinet, S., Smith, M., and Stevens, C.: Experimental and Numerical Study of the Turbulence Characteristics of Airflow around a Research Vessel, *Journal of Atmospheric and Oceanic Technology*, 21, 1575–1589, [https://doi.org/10.1175/1520-1010.0426\(2004\)021<1575:EANSOT>2.0.CO;2](https://doi.org/10.1175/1520-1010.0426(2004)021<1575:EANSOT>2.0.CO;2), 2004.
- Protat, A., Schulz, E., Rikus, L., Sun, Z., Xiao, Y., and Keywood, M.: Shipborne observations of the radiative effect of Southern Ocean clouds, *Journal of Geophysical Research: Atmospheres*, 122, 318–328, <https://doi.org/10.1002/2016JD026061>, 2017.
- Read, K., Lewis, A., Bauguitte, S., Rankin, A., Salmon, R., Wolff, E., Saiz-Lopez, A., Bloss, W., Heard, D., Lee, J., and Plane, J.: DMS and MSA measurements in the Antarctic Boundary Layer: impact of BrO on MSA production, *Atmospheric Chemistry and Physics*, 8, 2985–2997, 2008.
- Rose, D., Gunthe, S. S., Mikhailov, E., Frank, G. P., Dusek, U., Andreae, M. O., and Pöschl, U.: Calibration and measurement uncertainties of a continuous-flow cloud condensation nuclei counter (DMT-CCNC): CCN activation of ammonium sulfate and sodium chloride aerosol particles in theory and experiment, *Atmospheric Chemistry and Physics*, 8, 1153–1179, <https://doi.org/10.5194/acp-8-1153-2008>, 2008.
- Rosenfeld, D., Andreae, M., Asmi, A., Chin, M., Leeuw, G., Donovan, D., Kahn, R., Kinne, S., Kivekäs, N., Kulmala, M., Lau, W., Schmidt, K., Suni, T., Wagner, T., Wild, M., and Quaas, J.: Global observations of aerosol-cloud-precipitation-climate interactions, *Reviews of Geophysics*, 52, 750–808, <https://doi.org/10.1002/2013RG000441>, 2014.
- Salter, M. E., Nilsson, E. D., Butcher, A., and Bilde, M.: On the seawater temperature dependence of the sea spray aerosol generated by a continuous plunging jet, *Journal of Geophysical Research: Atmospheres*, 119, 9052–9072, <https://doi.org/10.1002/2013JD021376>, 2014.
- Saltzman, E. S., King, D. B., Holmen, K., and Leck, C.: Experimental determination of the diffusion coefficient of dimethylsulfide in water, *Journal of Geophysical Research: Oceans*, 98, 16 481–16 486, <https://doi.org/10.1029/93JC01858>, 1993.
- Schmale, J., Baccarini, A., Thurnherr, I., Henning, S., Efraim, A., Regayre, L., Bolas, C., Hartmann, M., Welti, A., Lehtipalo, K., Aemisegger, F., Tatzelt, C., Landwehr, S., Modini, R., Tummon, F., Johnson, J., Harris, N., Schnaiter, M., Toffoli, A., Derkani, M., Bukowiecki, N., Stratmann, F., Dommen, J., Baltensperger, U., Wernli, H., Rosenfeld, D., Gysel-Beer, M., and Carslaw, K.: Overview of the Antarctic Circumnavigation Expedition: Study of Preindustrial-like Aerosols and Their Climate Effects (ACE-SPACE), *Bulletin of the American Meteorological Society*, 100, 2260–2283, <https://doi.org/10.1175/BAMS-D-18-0187.1>, 2019.
- Schuddeboom, A., Varma, V., McDonald, A. J., Morgenstern, O., Harvey, M., Parsons, S., Field, P., and Furtado, K.: Cluster-Based Evaluation of Model Compensating Errors: A Case Study of Cloud Radiative Effect in the Southern Ocean, *Geophysical Research Letters*, 46, 3446–3453, <https://doi.org/10.1029/2018GL081686>, 2019.
- Smith, S. R., Briggs, K., Bourassa, M. A., Elya, J., and Paver, C. R.: Shipboard automated meteorological and oceanographic system data archive: 2005–2017, *Geoscience Data Journal*, 5, 73–86, <https://doi.org/10.1002/gdj3.59>, 2018.
- Spinhirne, J. D., RALL, J. A., and SCOTT, V. S.: Compact eye safe lidar systems, *The Review of Laser Engineering*, 23, 112–118, 1995.
- Stolzenburg, M.: An Ultrafine Aerosol Size Distribution Measuring System, Ph.D. thesis, University of Minnesota, 1988.
- Stubbins, A., Uher, G., Law, C. S., Mopper, K., Robinson, C., and Upstill-Goddard, R. C.: Open-ocean carbon monoxide photoproduction, *Deep Sea Research Part II: Topical Studies in Oceanography*, 53, 1695 – 1705, <https://doi.org/https://doi.org/10.1016/j.dsr2.2006.05.011>, 2006.



- Swinerton, J. W. and Lamontagne, R. A.: Carbon monoxide in the South Pacific Ocean1, *Tellus*, 26, 136–142, <https://doi.org/10.1111/j.2153-3490.1974.tb01959.x>, 1974.
- Trenberth, K. E. and Fasullo, J. T.: Tracking Earth's Energy, *Science*, 328, 316–317, <https://doi.org/10.1126/science.1187272>, 2010.
- Vali, G.: Quantitative Evaluation of Experimental Results an the Heterogeneous Freezing Nucleation of Supercooled Liquids, *Journal of the Atmospheric Sciences*, 28, 402–409, [https://doi.org/10.1175/1520-0469\(1971\)028<0402:QEOERA>2.0.CO;2](https://doi.org/10.1175/1520-0469(1971)028<0402:QEOERA>2.0.CO;2), 1971.
- 1045 Vana, M., Virkkula, A., Hirsikko, A., Aalto, P., Kulmala, M., and Hillamo, R.: Air Ion Measurements During a Cruise from Europe to Antarctica, in: *Nucleation and Atmospheric Aerosols*, edited by O'Dowd, C. D. and Wagner, P. E., pp. 368–372, Springer Netherlands, Dordrecht, 2007.
- Vergara-Temprado, J., Miltenberger, A., Furtado, K., Grosvenor, D., Shipway, B., Hill, A., Wilkinson, J., Field, P., Murray, B., and Carslaw, 1050 K.: Strong control of Southern Ocean cloud reflectivity by ice-nucleating particles, *Proceedings of the National Academy of Sciences*, <https://doi.org/10.1073/pnas.1721627115>, 2018.
- Wagner, T. J. and Kleiss, J. M.: Error Characteristics of Ceilometer-Based Observations of Cloud Amount, *Journal of Atmospheric and Oceanic Technology*, 33, 1557–1567, <https://doi.org/10.1175/JTECH-D-15-0258.1>, 2016.
- Walker, C., Harvey, M., Smith, M., Bell, T., Saltzman, E., Marriner, A., McGregor, J., and Law, C.: Assessing the potential for DMS 1055 enrichment at the sea-surface and its influence on air-sea flux, *Ocean Science Discussions*, <https://doi.org/10.5194/os-2016-26>, 2016.
- Ware, J., Kort, E. A., DeCola, P., and Duren, R.: Aerosol lidar observations of atmospheric mixing in Los Angeles: Climatology and implications for greenhouse gas observations, *Journal of Geophysical Research: Atmospheres*, 121, 9862–9878, <https://doi.org/10.1002/2016JD024953>, 2016.
- Welti, A., Bigg, E. K., DeMott, P. J., Gong, X., Hartmann, M., Harvey, M., Henning, S., Herenz, P., Hill, T. C. J., Hornblow, B., Leck, C., 1060 Löffler, M., McCluskey, C. S., Rauker, A. M., Schmale, J., Tatzelt, C., van Pinxteren, M., and Stratmann, F.: Ship-based measurements of ice nuclei concentrations over the Arctic, Atlantic, Pacific and Southern Ocean, *Atmospheric Chemistry and Physics Discussions*, 2020, 1–22, <https://doi.org/10.5194/acp-2020-466>, 2020.
- Williams, R. T. and Bainbridge, A. E.: Dissolved CO, CH<sub>4</sub>, and H<sub>2</sub> in the Southern Ocean, *Journal of Geophysical Research*, 78, 2691–2694, <https://doi.org/10.1029/JC078i015p02691>, 1973.
- 1065 Wilson, D. F., Swinerton, J. W., and Lamontagne, R. A.: Production of Carbon Monoxide and Gaseous Hydrocarbons in Seawater: Relation to Dissolved Organic Carbon, *Science*, 168, 1577–1579, <https://doi.org/10.1126/science.168.3939.1577>, 1970.
- Wingenter, O. W., Haase, K. B., Strutton, P., Friederich, G., Meinardi, S., Blake, D. R., and Rowland, F. S.: Changing concentrations of CO, CH<sub>4</sub>, C<sub>2</sub>H<sub>6</sub>, CH<sub>3</sub>Br, CH<sub>3</sub>I, and dimethyl sulfide during the Southern Ocean Iron Enrichment Experiments, *Proceedings of the National Academy of Sciences*, 101, 8537–8541, <https://doi.org/10.1073/pnas.0402744101>, 2004.
- 1070 Yan, J., Jung, J., Zhang, M., Bianchi, F., Tham, Y. J., Xu, S., Lin, Q., Zhao, S., Li, L., and Chen, L.: Uptake selectivity of methanesulfonic acid (MSA) on fine particles over polynya regions of the Ross Sea, Antarctica, *Atmospheric Chemistry and Physics*, 20, 3259–3271, <https://doi.org/10.5194/acp-20-3259-2020>, 2020.
- Yang, M., Blomquist, B. W., Fairall, C. W., Archer, S. D., and Huebert, B. J.: Air-sea exchange of dimethylsulfide in the Southern Ocean: Measurements from SO GasEx compared to temperate and tropical regions, *Journal of Geophysical Research: Oceans*, 116, 1075 <https://doi.org/10.1029/2010JC006526>, 2011.